



ODU MINI-SNAP PC

Miniature Cylindrical Connectors
with
Push-Pull-Locking
in Plastic



The latest version of this catalogue
is posted on our websites:
www.odu.de or www.odu-usa.com

UL-File E110586 01 RT07175

All data and specifications subject
to change without notice.
All dimensions in mm.
All pictures are illustrations.



2 rue René Laennec 51500 Taissy France
Fax: 03 26 85 19 08, Tel : 03 26 82 49 29

E-mail: hvssystem@hvssystem.com
Site web : www.hvssystem.com

| | |
|---|----|
| Introduction | 5 |
| Product description | 6 |
| Applications | 7 |
| General Product Information | 9 |
| Important Issues At A Glance | 10 |
| Straight Plugs | 11 |
| Receptacles | 12 |
| In-Line Receptacles | 13 |
| Stamped and formed contacts | 14 |
| Stamped and formed contacts - processing | 15 |
| Turned contacts | 17 |
| Compatibility | 18 |
| Inserts | 18 |
| Special designs for the ODU MINI-SNAP PC | 19 |
| Watertight connectors, IP 68 | 20 |
| Shielded version, > 60 dB | 21 |
| Receptacle „disposable“ = One-Way-Version | 22 |
| Autoclaving | 23 |
| Part Number Key | 25 |
| Dimensions | 28 |
| Straight Plugs | 28 |
| Receptacles | 29 |
| In-Line Receptacles | 30 |
| Type Definition | 31 |
| Straight plugs | 32 |
| Receptacles | 33 |
| In-Line Receptacles | 34 |
| Inserts and Contact Configurations | 35 |
| Size 1 | 36 |
| Size 2 | 38 |
| Size 3 | 40 |
| More details for the Part Number Key | 43 |
| Coding, Housing | 44 |
| Insulation body material | 45 |
| Contact type, Contact diameter | 46 |
| Contact - Termination Cross Section (AWG) | 47 |
| Collet systems | 49 |
| Right-Angled PCB-Version | 51 |
| Bend Protection Sleeves | 52 |
| Technical Informations for the ODU MINI-SNAP PC | 53 |
| Current Load - Contacts | 54 |
| Housing materials, Insulation body materials PBT + PEEK | 56 |
| Mating Force, Demating Force and Pull-Off-Force | 57 |
| Electromagnetic Compatibility (EMC) | 58 |
| Autoclaving of MINI-SNAP PC | 59 |
| Accessories | 61 |
| Toolings | 65 |



| | |
|---|----|
| Assembly Instructions | 73 |
| General Technical Informations | 79 |
| International Protection (IP) Classes (DIN EN 60 529) | 80 |
| Insulation Groups / Nominal Voltage / Test Voltage | 81 |
| Termination Styles | 83 |
| Conversion Table AWG to Metric | 85 |
| Quality Management | 86 |
| Technical Terms & Definitions | 87 |
| Inquiry Form (Fax) | 91 |
| Part Number Key for Open Out | 92 |



Introduction



ODU MINI-SNAP PC: The Connector with Push-Pull-Locking in Plastic

Cylindrical Connectors are generally available with several locking mechanisms:

The most frequently used are:

- Threaded-Locking Sleeve
- Bayonet-Locking
- Push-Pull-Locking

Push-Pull-Connectors have a very simple locking mechanism:

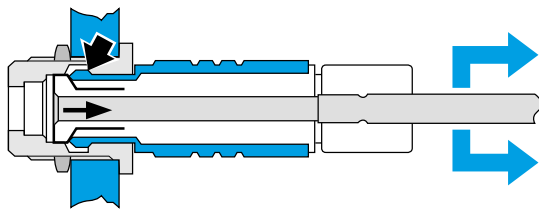

Pulling on the cable or on the back nut causes the locking fingers to grip tighter into the groove inside receptacle. A separation is virtually impossible.

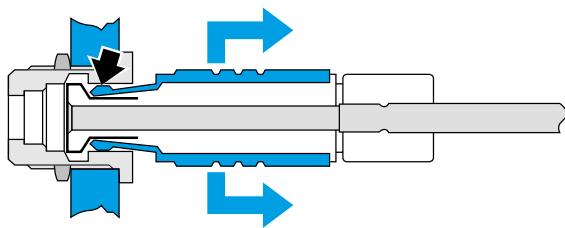

Pulling on the outer plug housing disengages the locking fingers from the receptacle groove and the connector separates easily.

The Advantages of Push-Pull-Connectors:

- Quick and easy mating and demating
- Easy blind mating in difficult to-reach places
- Less panel space required
- Definite and secure locking condition
- Less mating required

Applications



Medical

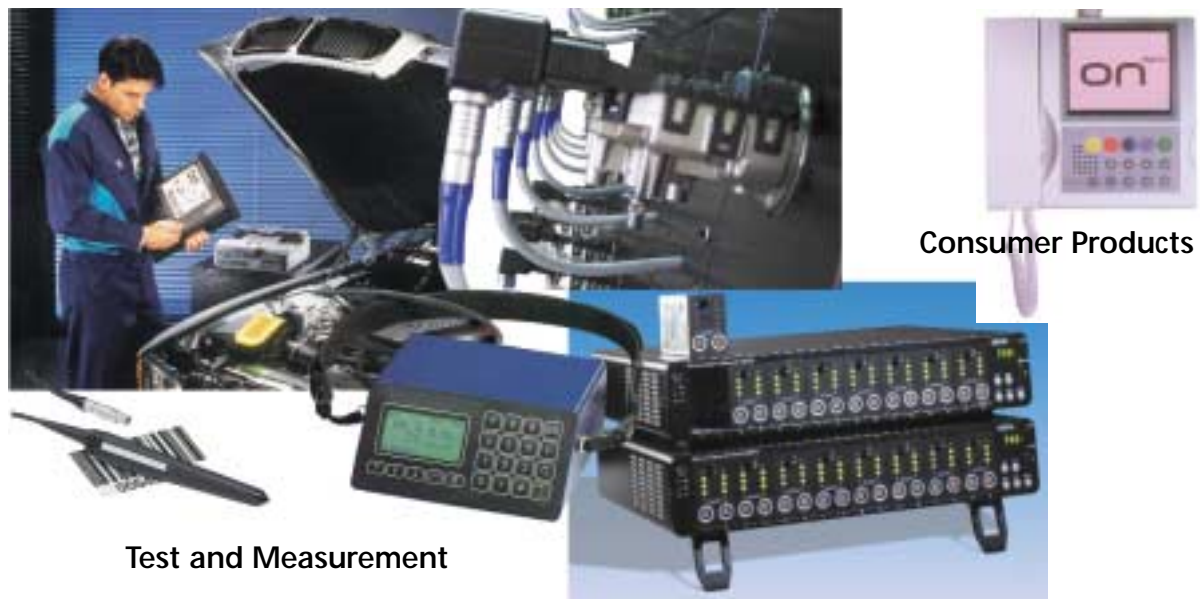

Consumer Products

Test and Measurement



Commercial Electronic

Industrial Electronic





General Product Information



Important Issues At A Glance:

- The series is certificated for  and VDE.
 - **Connector with plastic housing available in 3 sizes**
Outside diameter between 12,5 mm and 19 mm
Number of contact positions: 2 to 27 position
 - **With solder-, crimp and print termination available**
 - **Operation temperature: - 40 °C - + 120 °C**
 - **Compatible to ODU MINI-SNAP Series F & W.W. Fischer™**
(Must be checked)
 - **5000 Mating Cycles with all contact types**
 - **High Economy:**
 - Automatic crimping
 - Easy mounting of the contacts
 - Easy mounting from the connector
 - Economic solutions
 - **Further Advantages:**
 - 100 % touch protection
 - Low weight
 - Low mating forces
 - Non magnetic
 - Autoclavable, chemical resistant
 - **Special designs**
 - Watertight version, IP 68
 - Shielded version
 - Disposable = One-Way-Version
 - Autoclavable version
-

Plug, Style 1, IP 50

Inner parts (sleeve and cable collet in plastic)

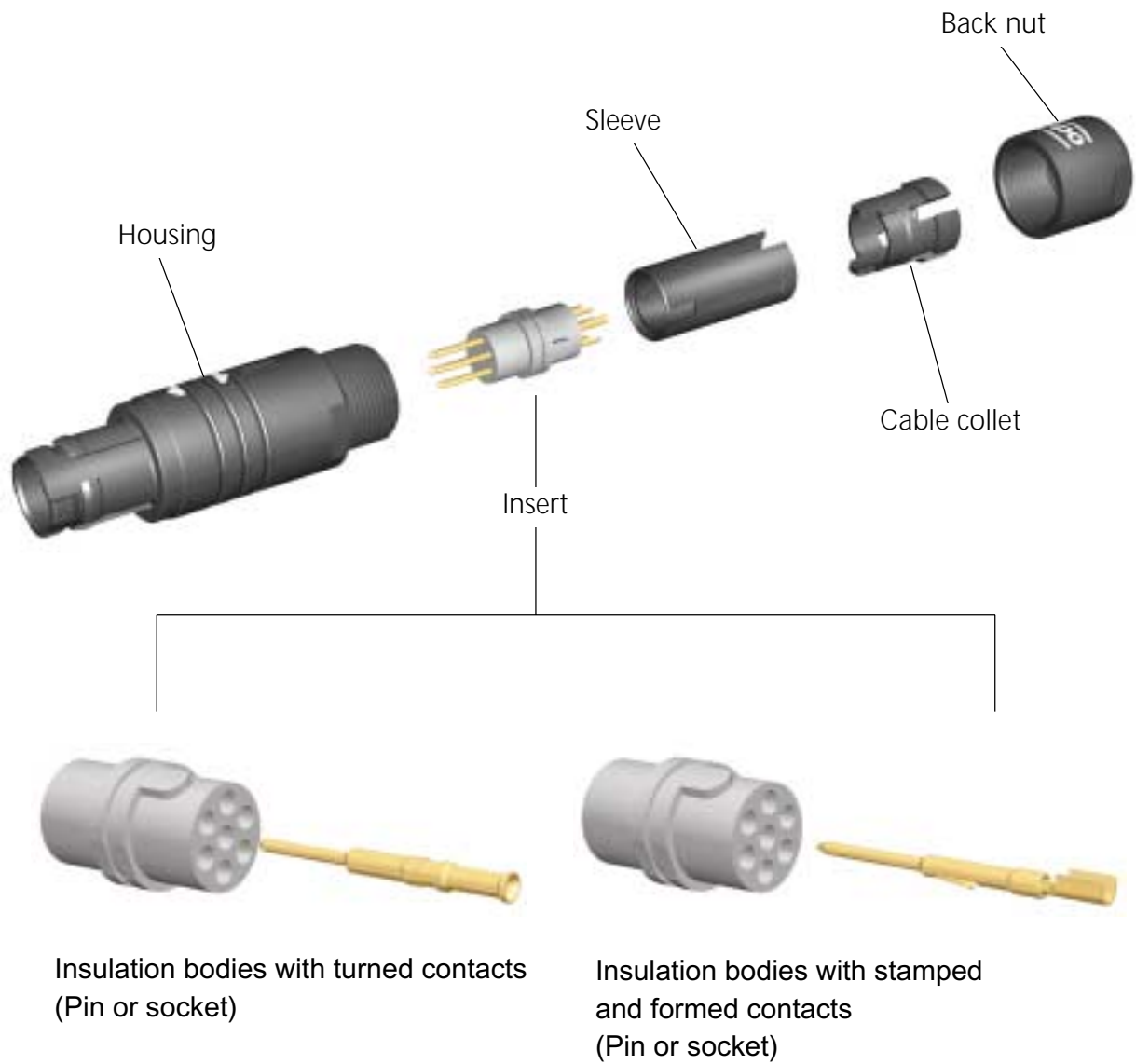

- Easy and fast assembling
- The long housing guiding groove makes blind assembling possible

Receptacle, Style 1, IP 50

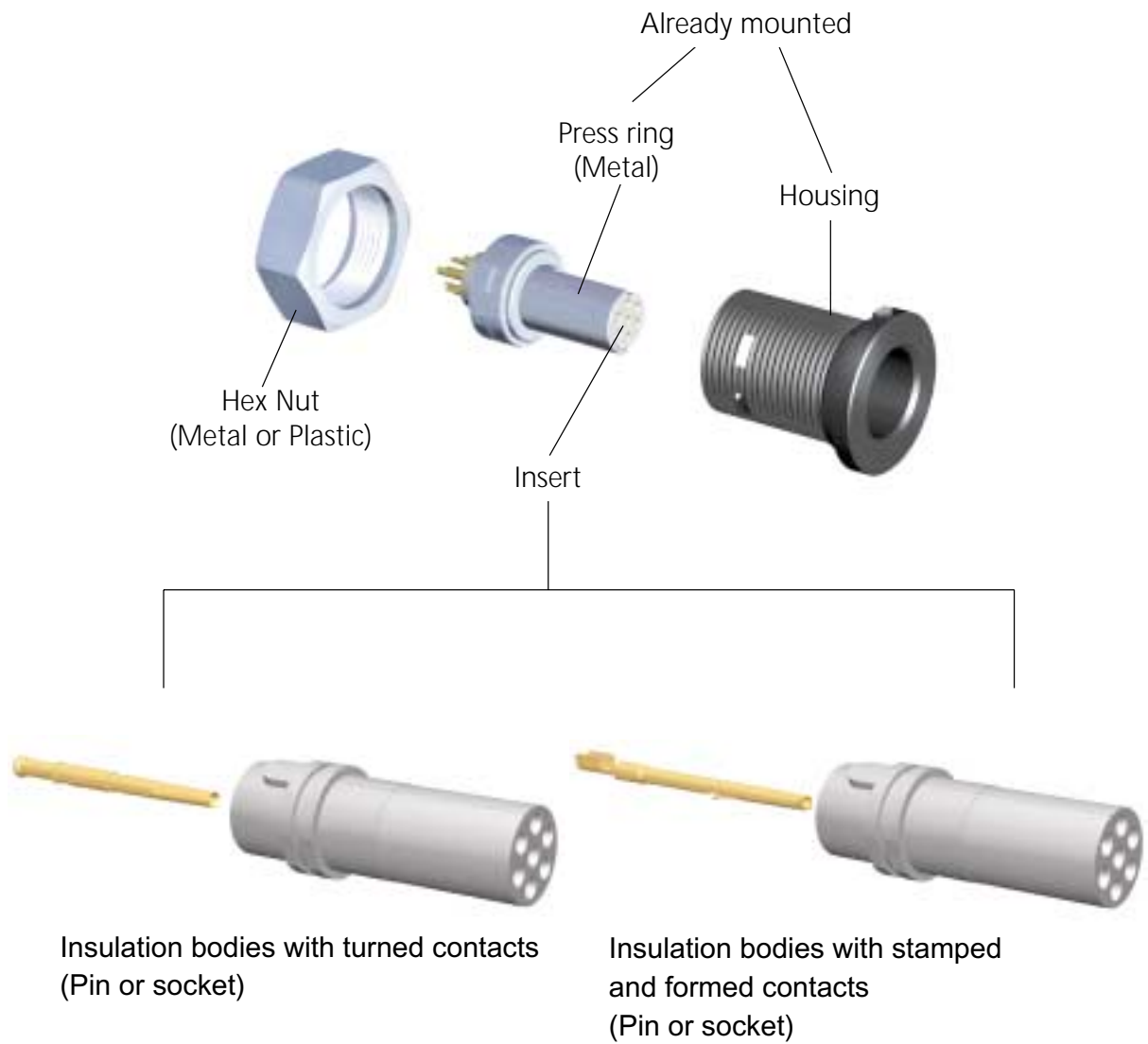

● Other styles see page 29

In-Line Receptacle, Style 1, IP 50

Inner part (cable collet) in plastic

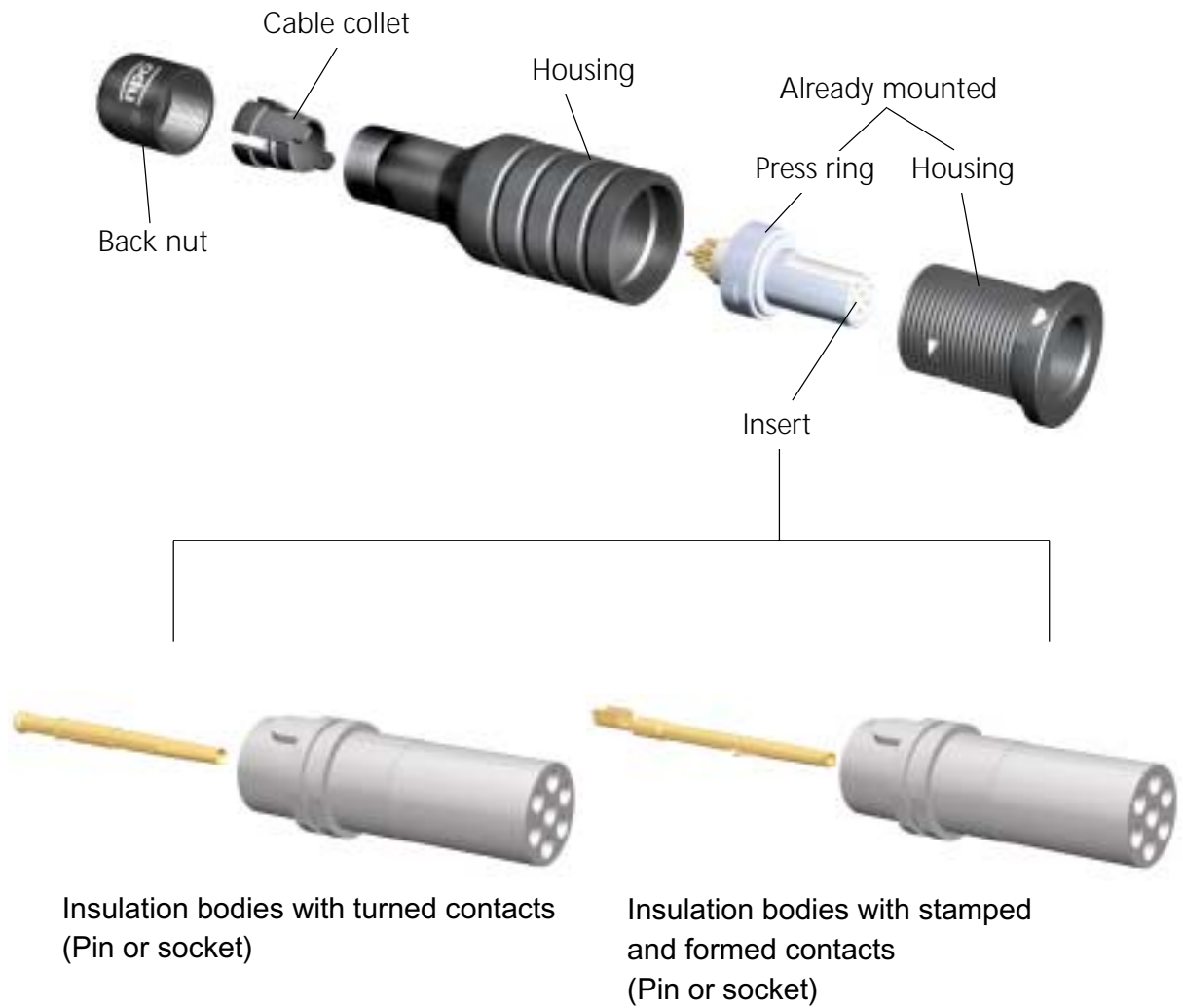

- Easy and fast assembling

Stamped and formed contact, Ø 0,7 mm

For the ODU MINI-SNAP PC a stamped contact Ø 0.7 mm has been developed which is mating compatible with the turned contacts Ø 0.7 mm. The stamped contact has an integrated clip. The crimp version can be inserted into the insulation body and engaged by the customer easily without any tool.

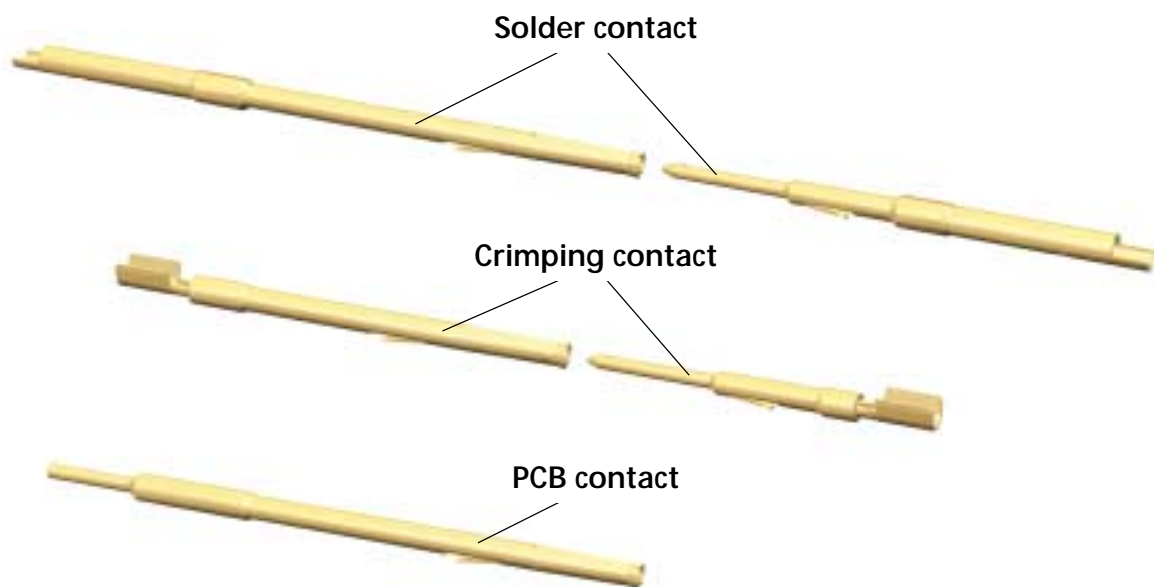

Contact type and contact diameter:

| | |
|-----------------------|---|
| Crimp: | AWG 26/28; 0,15 / 0,08 mm ² AWG 22/24; 0,38 / 0,25 mm ² |
| Solder: | AWG 22; max. 0,38mm ² |
| PCB: | Ø 0,7 mm -> only socket available |
| Mating cycles: | > 5000 |
| Mating force: | ~ 0,3 N |
| Current Load: | 4A / AWG 26 |
| Material: | Bronze |
| Treatment Processing: | cpl. Contact 1,25 µm Ni Mating area: At least +0,75 µm Au Termin. area: At least +3 µm SnPb |

Stamped and formed contacts - processing

For stamped contacts with crimp termination there are new options:

Stripper-Crimper for automatic crimping

Automatic crimping machines can be used on cables which have been stripped to a very short length. Consequently they are ideally suited for the ODU MINI-SNAP PC.

To order by:

Fa. Schäfer

Werkzeug- und Sondermaschinen GmbH

Dr.-Alfred-Weckesser-Strasse 6

D-76669 Bad Schönborn-La.

Phone: 0 72 53 / 94 21-0

Fax: 0 72 53 / 94 21-94

Internet: www.schaefer-werkzeugbau.com

eMail: info@schaefer-werkzeugbau.com



Hand Crimp Tool with reel (080.000.041.000.000)

The hand crimping tool feeds the contact on a tape and the contacts are separated automatically during the crimping process. Contacts are moved forward by hand operation.



Hand Crimp Tool for Single-contact-processing (see next page)



Stamped and formed contacts - processing

For stamped contacts with crimp termination there are new options:

**Hand Crimp Tool for
single contacts
(080.000.040.000.000)**

Here Single Contacts are inserted into
the tong manually and are crimped.



Turned contact

Turned contacts are available from the metal version **ODU MINI-SNAP** in the diameters of 0.5 to 2.0 mm.

The contacts are available with following terminations:

- Solder
- Crimp
- PCB

Standard Pin

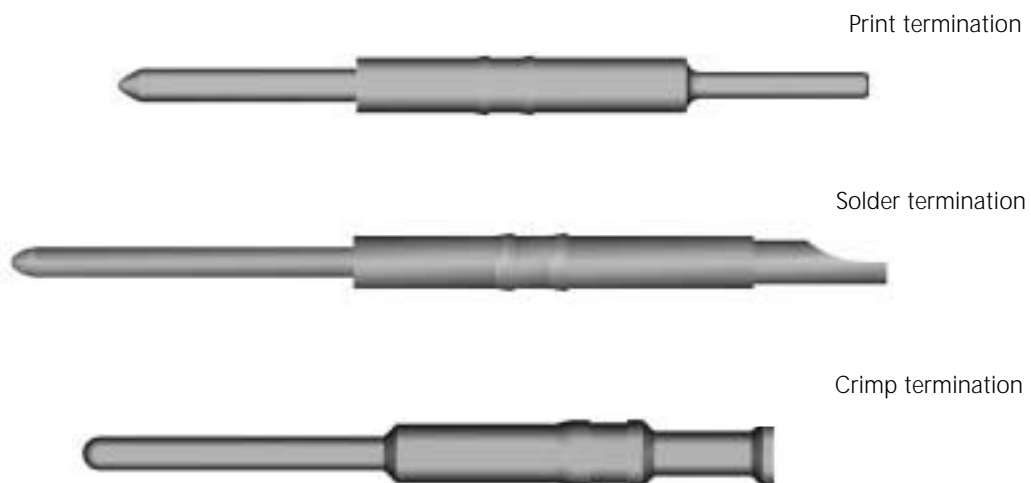

| | |
|----------------|--|
| Mating cycles: | > 5000 |
| Material: | Brass |
| Plating: | At least 1,25 μm Ni; at least 0,75 μm Au |

**Informations for diameter, termination styles and current load
please find by the inserts (Page 36)**



Compatibility

ODU MINI-SNAP PC is intermatable with the metal version Series F. A part from this, when choosing the right inserts, the connector is intermatable with products of W.W. Fischer™ (must be checked).

Inserts

ODU MINI-SNAP PC has been developed on the basis of the metal version [ODU MINI-SNAP](#). **Accordingly a lot of inserts of the series F and series B from the metal version in sizes 1, 2, and 3 can be inserted into the MINI-SNAP PC.** Approx. 100 different contact configurations are available right now.



Special designs

Special designs

Watertight version (IP 68)

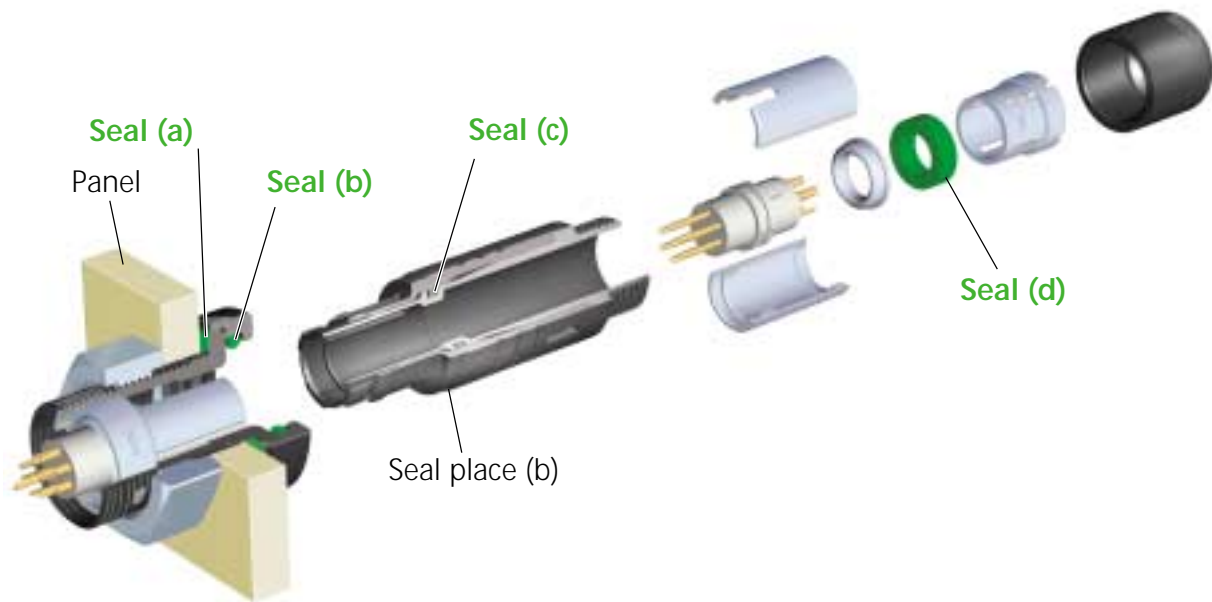

Seal (a): Sealing between the receptacle and the panel

Seal (b): Sealing between the plug and the receptacle

Seal (c): Sealing between the both plug housings

Seal (d): Sealing between the cable and the plug

Receptacle IP 68 (Style E)

- IP 68 in mated condition or with protective cover (see page 63)
- Receptacle is not potted
- For all Types (see page 33)

Plug IP 68 (Style 3 & 4)

- IP 68 in mated condition
- with metall inner parts (Type A/C see page 32)

The watertight version is also shielded available.

Shielded Version with plastic inner parts

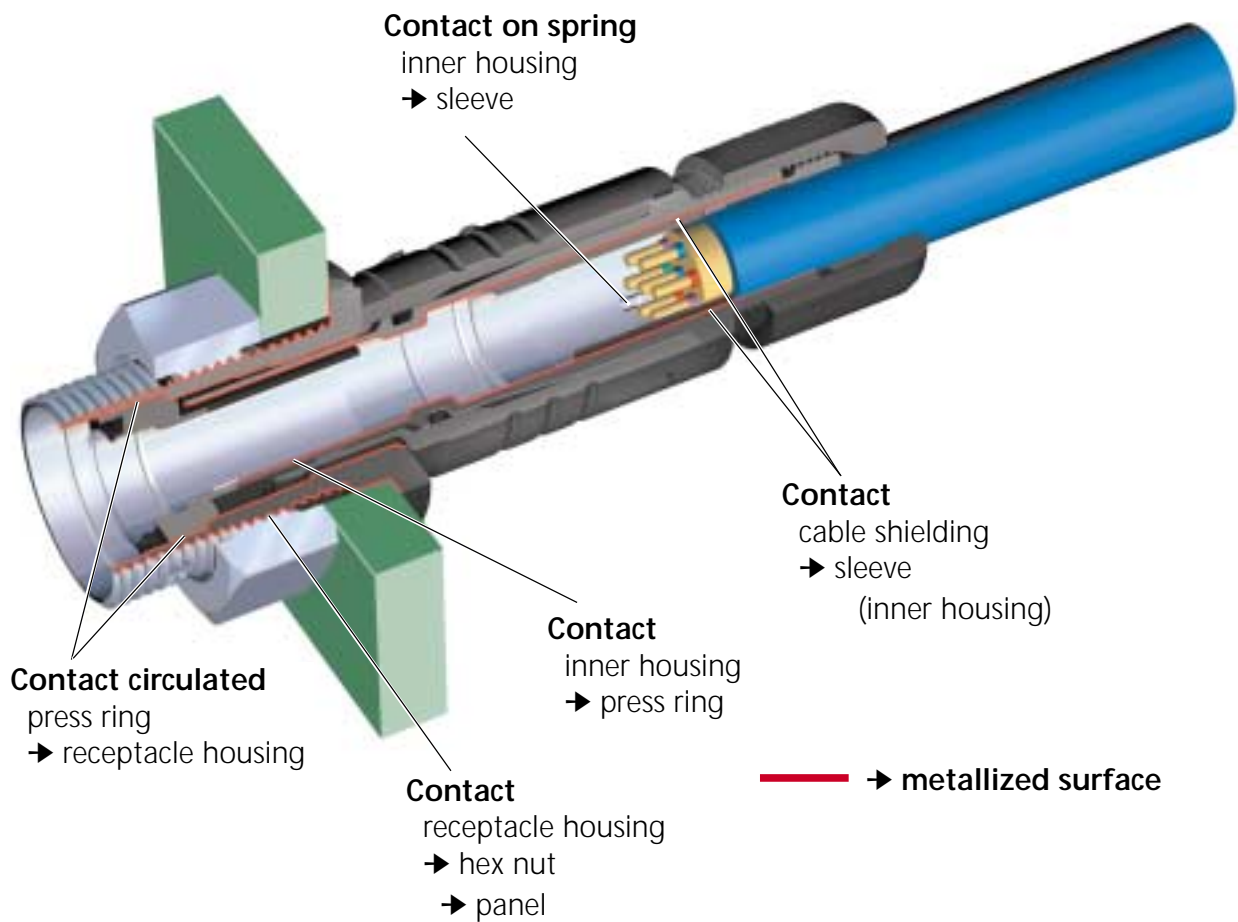

The shielded version is realized by metallizing several components. In spite of the metallizing the connector in mated condition remains 100 % touch proof.

| | |
|---------------------|---|
| Plating: | 5 μm Cu + 2 μm Ni |
| Mating cycles: | At least 100 Cycles |
| Contact resistance: | < 20 m Ω |
| Attenuation: | > 60 dB |
| Autoclaving cycles: | At least 100 Cycles (DIN EN 13060) |

Disposable / One-Way-Version

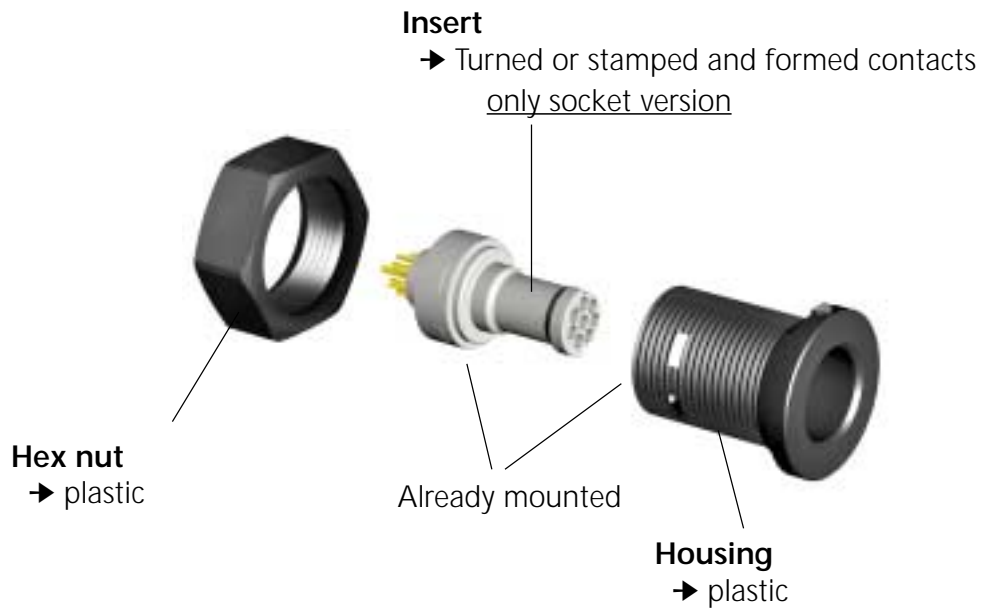

- Custom specific connector (on request)
- Not in shielded version available
- Only with socket insert available

Autoclaving of the insulation bodies

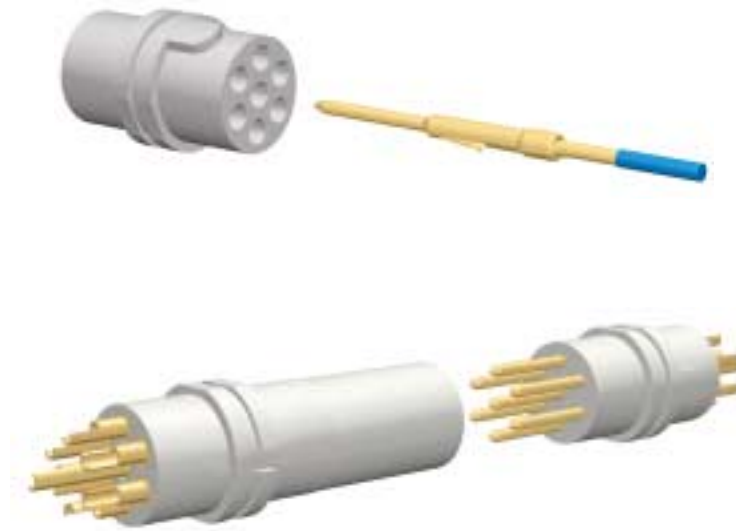

The insulation body materials are **PBT** (Standard) or **PEEK**

- For Autoclaving - connectors we always use PEEK.
(Disposable on request)



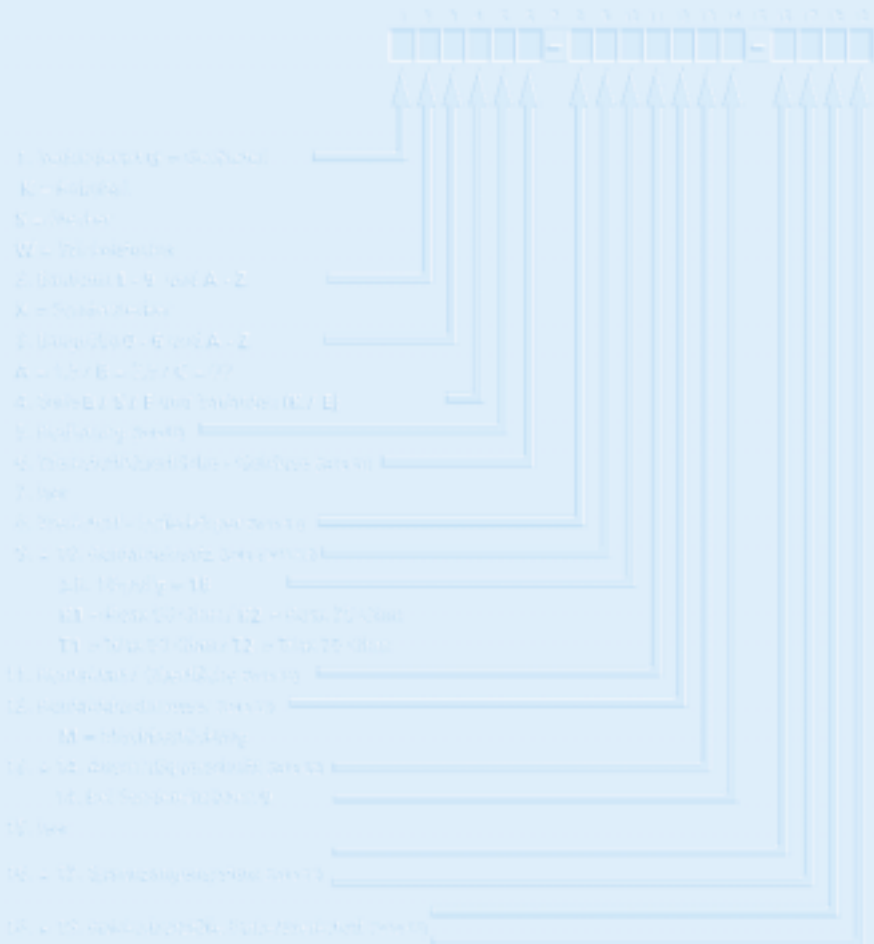

- 1. Terminal 1 - 24
- 2. Terminal 1 - 2
- 3. Terminal 1 - 2
- 4. Terminal 1 - 2
- 5. Terminal 1 - 2
- 6. Terminal 1 - 2
- 7. Terminal 1 - 2
- 8. Terminal 1 - 2
- 9. Terminal 1 - 2
- 10. Terminal 1 - 2
- 11. Terminal 1 - 2
- 12. Terminal 1 - 2
- 13. Terminal 1 - 2
- 14. Terminal 1 - 2
- 15. Terminal 1 - 2
- 16. Terminal 1 - 2
- 17. Terminal 1 - 2
- 18. Terminal 1 - 2
- 19. Terminal 1 - 2
- 20. Terminal 1 - 2
- 21. Terminal 1 - 2
- 22. Terminal 1 - 2
- 23. Terminal 1 - 2
- 24. Terminal 1 - 2



Part Number Key Dimensions and Contact Configurations



Part Number Key ODU MINI-SNAP PC

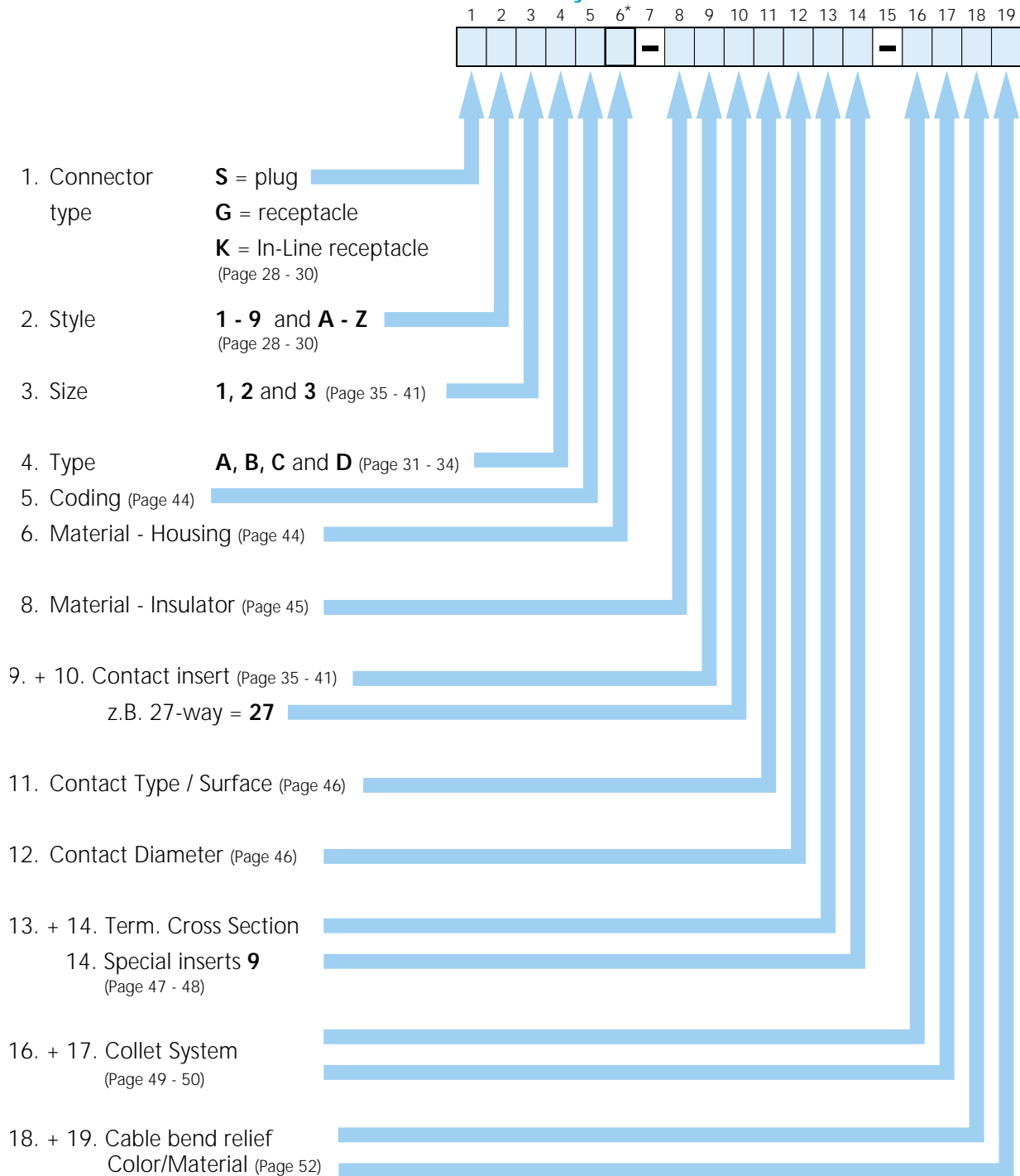

Example:

| 1 | 2 | 3 | 4 | 5 | 6 | 7 | 8 | 9 | 10 | 11 | 12 | 13 | 14 | 15 | 16 | 17 | 18 | 19 |
|---|---|---|---|---|---|---|---|---|----|----|----|----|----|----|----|----|----|----|
| S | 4 | 1 | A | 1 | 8 | - | T | 0 | 7 | 4 | F | Z | 0 | - | 4 | 5 | G | P |

Plug – IP 68 – Size 1 – Type A – Coding 1 – Black plastic housing – PBT insulator – 7-way stamped and formed Crimp-Pin – AWG 28-26 – Cable diam. 4,1-4,5 mm – Black Cable Bend Relief - Material PUR

* If in field number 6 there is a 3 or 8, and in field number 4 there is a A, B, C, or D, it can be seen right away that this product is a Push-Pull Connector of the plastic PC version.

Part Number Key

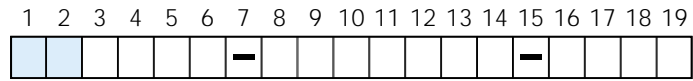

Straight Plug

(Suitable for all following receptacles and In-Line-Receptacles)

- S 1** - IP 50 – With Standard Back Nut
- S 2** - IP 50 – With Back Nut for Cable Bend Relief
- S 3** - IP 68 – Watertight with Standard Back Nut
- S 4** - IP 68 – Watertight with Back Nut for Cable Bend Relief

Contact configuration from page 36

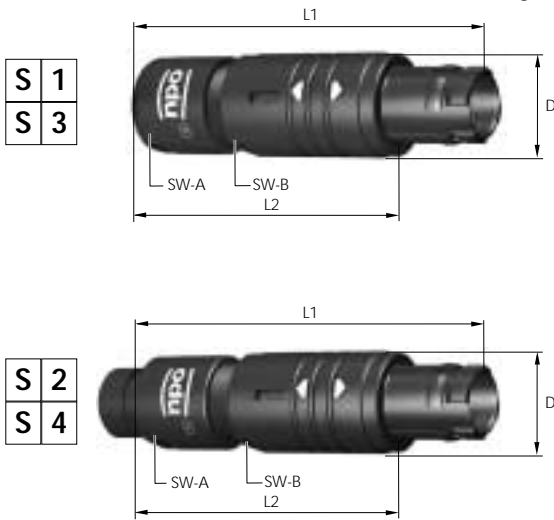

| Size | Dimensions in mm | | | | |
|------|------------------|------|------|------|------|
| | L1 | L2 | D | SW-A | SW-B |
| 1 | ~ 46 | ~ 35 | 12,5 | 11 | 11 |
| 2 | ~ 52 | ~ 39 | 15 | 13 | 13 |
| 3 | ~ 59 | ~ 45 | 19 | 16 | 17 |

Part Number Key

Dimensions ODU MINI-SNAP PC

| | | | | | | | | | | | | | | | | | | |
|---|---|---|---|---|---|---|---|---|----|----|----|----|----|----|----|----|----|----|
| 1 | 2 | 3 | 4 | 5 | 6 | 7 | 8 | 9 | 10 | 11 | 12 | 13 | 14 | 15 | 16 | 17 | 18 | 19 |
| | | | | | | - | | | | | | | | | - | | | |

Receptacle

G 1 **Style 1** – ODU MINI-SNAP PC receptacle IP50, installation from front of panel

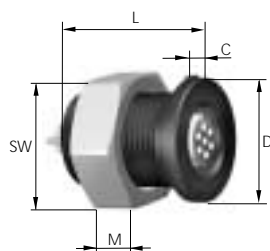

Technical Data

- IP 50
- anti-rotation feature
- contact configuration from page 36
- min. wall-thickness 1 mm

| Size | Dimensions in mm | | | | |  Panel Cut-Out |
|------|------------------|------|-----|-----|------|--|
| | L | D | C | M | SW | |
| 1 | 18,5 | 16,5 | 2,0 | 5,5 | 16,0 | SW 12,6 / Ø 13,6 |
| 2 | 20,5 | 21,0 | 2,0 | 5,5 | 19,0 | SW 15,6 / Ø 16,6 |
| 3 | 25,0 | 24,5 | 2,0 | 5,5 | 24,0 | SW 19,1 / Ø 21,1 |

G 5 **Style 5** – ODU MINI-SNAP PC receptacle IP50, continuous thread, installation from rear or front of panel. Front extension adjustable.

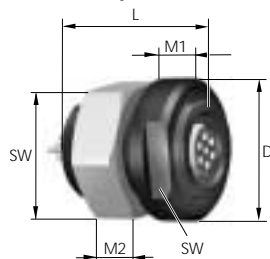

Technical Data

- IP 50
- anti-rotation feature
- contact configuration from page 36

| Size | Dimensions in mm | | | | |  Panel Cut-Out |
|------|------------------|------|-----|-----|------|--|
| | L | D | M1 | M2 | SW | |
| 1 | 18,5 | 19,0 | 5,0 | 5,5 | 16,0 | SW 12,6 / Ø 13,6 |
| 2 | 20,5 | 21,5 | 5,0 | 5,5 | 19,0 | SW 15,6 / Ø 16,6 |
| 3 | 25,0 | 28,0 | 5,0 | 5,5 | 24,0 | SW 19,1 / Ø 21,1 |

G E **Style E** – ODU MINI-SNAP PC receptacle IP 68, installation from front of panel.

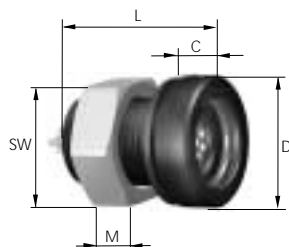

Technical Data

- IP 68
- contact configuration from page 36

| Size | Dimensions in mm | | | | |  Panel Cut-Out |
|------|------------------|------|------|-----|------|--|
| | L | D | C | M | SW | |
| 1 | 22,0 | 18,5 | -6,0 | 5,5 | 16,0 | SW 12,6 / Ø 13,6 |
| 2 | 24,0 | 22,5 | -6,0 | 5,5 | 19,0 | SW 15,6 / Ø 16,6 |
| 3 | 28,5 | 26,5 | -6,0 | 5,5 | 24,0 | SW 19,1 / Ø 21,1 |

Part Number Key

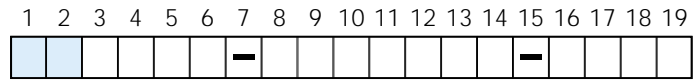

In-Line Receptacle

- K 1** - IP 50 – With Standard Back Nut
- K 2** - IP 50 – With Back Nut for Cable Bend Relief

Contact configuration from page 36

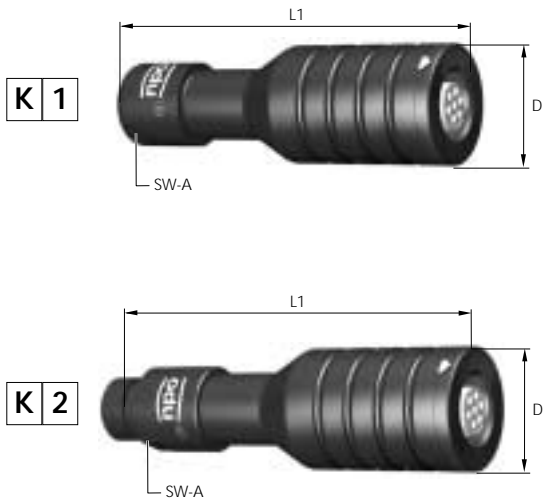

| Size | Dimensions in mm | | |
|------|------------------|------|------|
| | L1 | D | SW-A |
| 1 | 52,0 | 16,5 | 11,0 |
| 2 | 57,0 | 21,0 | 13,0 |
| 3 | 64,0 | 25,0 | 16,0 |

ODU MINI-SNAP PC In-Line Receptacle connect to plug for cable-to-cable connection.

For assembly use adhesive Scotch Weld DP 190 (ODU Number: 890 204 000 030 025) for thread locking of the housings.



Type define

Straight Plug

Part Number Key

| | | | | | | | | | | | | | | | | | | |
|---|---|---|---|---|---|---|---|---|----|----|----|----|----|----|----|----|----|----|
| 1 | 2 | 3 | 4 | 5 | 6 | 7 | 8 | 9 | 10 | 11 | 12 | 13 | 14 | 15 | 16 | 17 | 18 | 19 |
| S | | | | | | - | | | | | | | | - | | | | |

A Plug with Metal Inner Parts (IP68)

For style 3 and 4

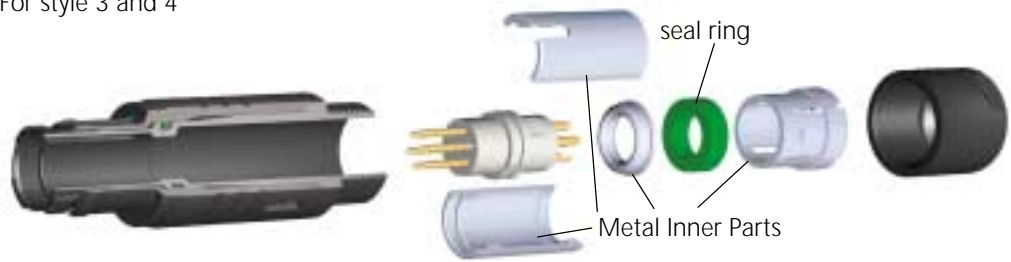

B Plug with Plastic Inner Parts (IP50)

For style 1 and 2



C Shielded Plug with Metal Inner Parts (IP68)

For style 3 and 4

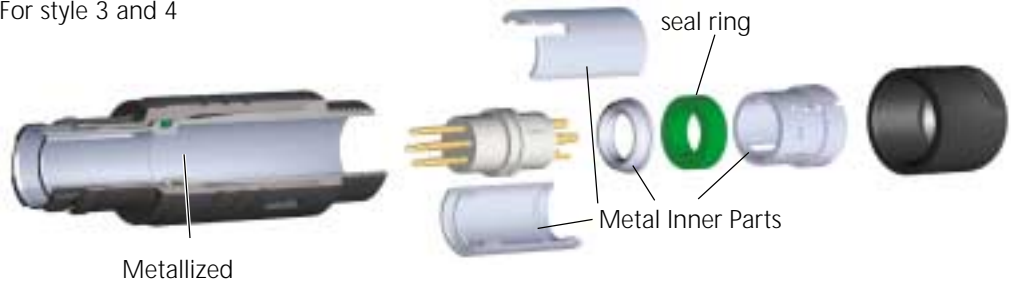

D Shielded Plug with Plastic Inner Parts (IP50)

For style 1 and 2

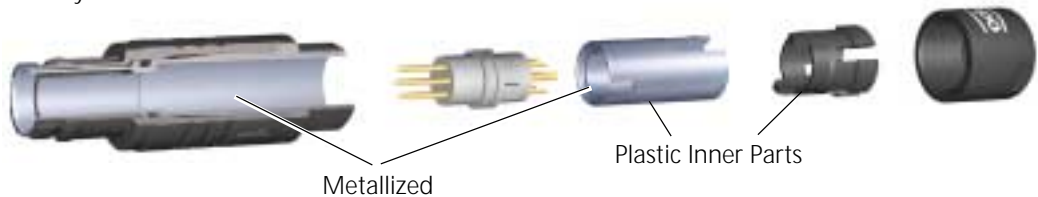

Receptacle

Type define ODU MINI-SNAP PC

Part Number Key

| | | | | | | | | | | | | | | | | | | |
|---|---|---|---|---|---|---|---|---|----|----|----|----|----|----|----|----|----|----|
| 1 | 2 | 3 | 4 | 5 | 6 | 7 | 8 | 9 | 10 | 11 | 12 | 13 | 14 | 15 | 16 | 17 | 18 | 19 |
| G | | | | | | - | | | | | | | | - | | | | |



A Receptacle with Metal Inner Part (press ring)

For all styles (IP50 and IP 68)

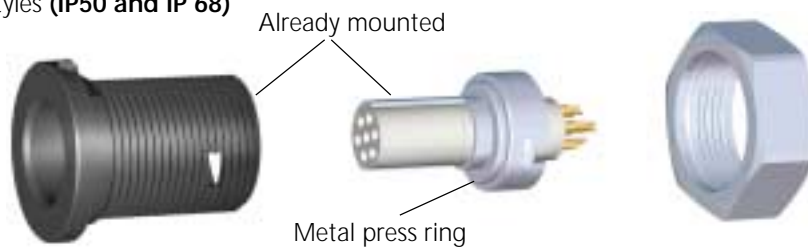

B Receptacle Disposable

All non conductive parts are made out of plastic

For all styles (IP50 and IP 68)

- Custom specific connector (on request)
- Not in shielded version available



C Shielded receptacle with Metal Inner Part (press ring)

For style 1 and E. (Style 5 on request)

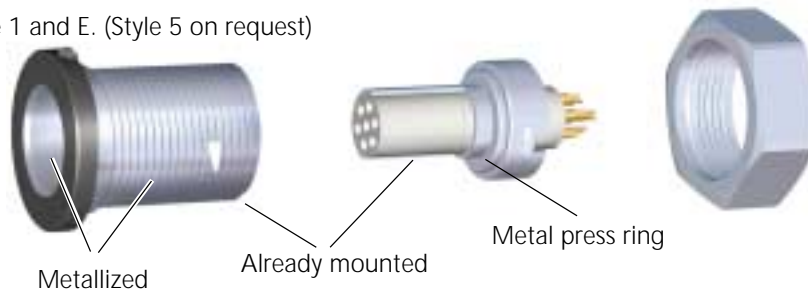

Notice: Receptacles are complete assembled



In-Line Receptacle

Part Number Key

| | | | | | | | | | | | | | | | | | | |
|---|---|---|---|---|---|---|---|---|----|----|----|----|----|----|----|----|----|----|
| 1 | 2 | 3 | 4 | 5 | 6 | 7 | 8 | 9 | 10 | 11 | 12 | 13 | 14 | 15 | 16 | 17 | 18 | 19 |
| K | | | | | | - | | | | | | | | - | | | | |



B

In-Line Receptacle with Plastic Cable Collet

For style 1 and 2 (IP 50)



Contact Configuration

PCB and solder contacts are factory-installed in the insulation body.
Crimp contacts are shipped separately.

Size 1, turned contacts

Part Number Key

| | | | | | | | | | | | | | | | | | | |
|---|---|---|---|---|---|---|---|---|----|----|----|----|----|----|----|----|----|----|
| 1 | 2 | 3 | 4 | 5 | 6 | 7 | 8 | 9 | 10 | 11 | 12 | 13 | 14 | 15 | 16 | 17 | 18 | 19 |
| | | 1 | | | | - | | | | | | | * | - | | | | |

| | Size | Positions | | Contact Ø mm (Termination cross section see page 47) | Rated current (A) (Derating factor see page 54) | Test voltage acc. VDE 0627:1986-06 (kVrms) | Test voltage acc. SAE AS13441:1998 method 3001.1 (kVrms) | Rated voltage acc. SAE AS13441:1998 method 3001.1 (kVrms) ¹⁾ | Terminations (Surface see page 81) | | | View on to termination area | |
|---|------|-----------|---|---|--|---|---|--|---------------------------------------|---|---|-----------------------------|-------------|
| | | | | | | | | | Solder | Crimp (Tools for assembly see page 66) | PCB (PCB layout and pin length on request) | Pin Part | Socket part |
| Standard Contact Configuration <small>compatible with other manufacturers</small> | 1 | 0 | 2 | 1,3 | 14 | 1,250 | 1,650 | 0,550 | ● | ● | ● | | |
| | 1 | 0 | 3 | 1,3 | 14 | 1,000 | 1,500 | 0,500 | ● | ● | ● | | |
| | 1 | 0 | 4 | 0,9 | 10 | 1,000 | 1,500 | 0,500 | ● | ● | ● | | |
| | 1 | 0 | 5 | 0,9 | 10 | 0,875 | 1,350 | 0,450 | ● | ● | ● | | |
| | 1 | 0 | 6 | 0,7 | 7 | 0,875 | 1,300 | 0,433 | ● | ● | ● | | |
| | 1 | 0 | 7 | 0,7 | 7 | 0,875 | 1,300 | 0,433 | ● | ● | ● | | |
| | 1 | 1 | 2 | 0,5 | 5 | 0,875 | 1,200 | 0,400 | ● | ● | | | |
| Special Contact Configuration <small>not compatible with other manufacturers</small> | 1 | 0 | 8 | 0,7 | 7 | 0,875 | 1,000 | 0,333 | ● | ● | ● | | |
| | 1 | 1 | 0 | 0,5 | 5 | 0,875 | 1,000 | 0,333 | ● | ● | | | |
| | 1 | 1 | 4 | 0,5 | 5 | 1,000 | 0,900 | 0,300 | ● | ● | | | |







* If you use a standard contact configuration, so please insert a "0".
If you use a special contact configuration, so please insert a "9".

1) Rated voltage acc. SAE AS 13441:1998 method 3001.1 corresponded MIL-STD 1344, method 3001, test acc. IEC 60512 test 4a. calculation method, caution and suggestion see page 80

Size 1, stamped and formed contacts

Part Number Key

| | | | | | | | | | | | | | | | | | | |
|---|---|---|---|---|---|---|---|---|----|----|----|----|----|----|----|----|----|----|
| 1 | 2 | 3 | 4 | 5 | 6 | 7 | 8 | 9 | 10 | 11 | 12 | 13 | 14 | 15 | 16 | 17 | 18 | 19 |
| | | 1 | | | | - | | | | | | | * | - | | | | |

| | Size | Positions | | Contact Ø mm (Termination cross section see page 48) | Rated current (A) (Operating factor see page 54) | Test voltage acc. VDE 0627:1986-06 (kVrms) | Test voltage acc. SAE AS13441:1998 method 3001.1 (kVrms) | Rated voltage acc. SAE AS13441:1998 method 3001.1 (kVrms) ¹⁾ | Terminations (Surface see page 81) | | | View on to termination area | |
|------------------------|------|-----------|---|---|---|---|---|--|---------------------------------------|---|---|---|---|
| | | | | | | | | | Solder | Crimp (Tools for assembly see page 66) | PCB ONLY SOCKET (PCB layout and pin length on request) | Pin Part | Socket part |
| Standard ^{1*} | 1 | 0 | 6 | 0,7 | 4 | 0,750 | 1,300 | 0,433 | ● | ● | ● |  |  |
| | 1 | 0 | 7 | 0,7 | 4 | 0,750 | 1,300 | 0,433 | ● | ● | ● |  |  |
| Special ^{2*} | 1 | 0 | 8 | 0,7 | 4 | 0,750 | 1,000 | 0,333 | ● | ● | ● |  |  |

^{1*} = Standard Contact Configuration
compatible with other manufacturers

^{2*} = Special Contact Configuration
not compatible with other manufacturers

* If you use a standard contact configuration, so please insert a "0".
If you use a special contact configuration, so please insert a "9".

1) Rated voltage acc. SAE AS 13441:1998 method 3001.1 corresponded MIL-STD 1344, method 3001, test acc. IEC 60512 test 4a. calculation method, caution and suggestion see page 80

2) The stamped crimp contacts are only with PEEK insulator available

Size 2, turned contacts

Part Number Key

| | | | | | | | | | | | | | | | | | | |
|---|---|---|---|---|---|---|---|---|----|----|----|----|----|----|----|----|----|----|
| 1 | 2 | 3 | 4 | 5 | 6 | 7 | 8 | 9 | 10 | 11 | 12 | 13 | 14 | 15 | 16 | 17 | 18 | 19 |
| | 2 | | | | | - | | | | | | | * | - | | | | |

* If you use a standard contact configuration, so please insert a "0".
If you use a special contact configuration, so please insert a "9".







| | Size | Positions | Positions | Contact Ø mm (Termination cross section see page 47) | Rated current (A) (Derating factor see page 54) | Test voltage acc. VDE 0627:1986:06 (kVrms) | Test voltage acc. SAE AS13441:1998 method 3001.1 (kVrms) | Rated voltage acc. SAE AS13441:1998 method 3001.1 (kVrms) ¹⁾ | Terminations (Surface see page 81) | | | View on to termination area | |
|---|------|-----------|-----------|---|--|---|---|--|---------------------------------------|---|---|-----------------------------|-------------|
| | | | | | | | | | Solder | Crimp (Tools for assembly see page 66) | PCB (PCB layout and pin length on request) | Pin Part | Socket part |
| Standard Contact Configuration <small>compatible with other manufacturers</small> | 2 | 0 | 6 | 0,9 | 10 | 1,250 | 2,100 | 0,700 | ● | ● | ● | | |
| | 2 | 1 | 1 | 0,9 | 10 | 1,000 | 1,500 | 0,500 | ● | ● | ● | | |
| | 2 | 1 | 6 | 0,7 | 7 | 1,000 | 1,500 | 0,500 | ● | ● | ● | | |
| | 2 | 1 | 9 | 0,7 | 7 | 0,875 | 1,200 | 0,400 | ● | ● | ● | | |
| Special Contact Configuration <small>not compatible with other manufacturers</small> | 2 | 0 | 3 | 1,6 | 17 | 1,500 | 2,400 | 0,800 | ● | ● | ● | | |
| | 2 | 0 | 6 | 1,3 | 14 | 1,250 | 1,500 | 0,500 | ● | ● | ● | | |
| | 2 | 0 | 8 | 0,9 | 10 | 1,250 | 1,500 | 0,500 | ● | ● | ● | | |
| | 2 | 1 | 0 | 0,9 | 10 | 1,250 | 1,500 | 0,500 | ● | ● | ● | | |
| | 2 | 1 | 2 | 0,7 | 7 | 1,000 | 1,350 | 0,450 | ● | ● | ● | | |

1) Rated voltage acc. SAE AS 13441:1998 method 3001.1 corresponded MIL-STD 1344, method 3001, test acc. IEC 60512 test 4a. calculation method, caution and suggestion see page 80

Size 2, stamped and formed contacts

Part Number Key

| | | | | | | | | | | | | | | | | | | |
|---|---|---|---|---|---|---|---|---|----|----|----|----|----|----|----|----|----|----|
| 1 | 2 | 3 | 4 | 5 | 6 | 7 | 8 | 9 | 10 | 11 | 12 | 13 | 14 | 15 | 16 | 17 | 18 | 19 |
| | 2 | | | | | - | | | | | | | * | - | | | | |

| | Size | Positions | | Contact Ø mm (Termination cross section see page 47) | Rated current (A) (Derating factor see page 48) | Test voltage acc. VDE 0627:1986-06 (kVrms) | Test voltage acc. SAE AS13441:1998 method 3001.1 (kVrms) | Rated voltage acc. SAE AS13441:1998 method 3001.1 (kVrms) ¹⁾ | Terminations (Surface see page 82) | | | View on to termination area | |
|------------------------|------|-----------|---|---|--|---|---|--|---------------------------------------|---|---|---|---|
| | | | | | | | | | Solder | Crimp (Tools for assembly see page 66) PCB (Only sockets) ²⁾ (PCB layout and pin length on request) | | | Pin Part |
| Standard ¹⁾ | 2 | 1 | 6 | 0,7 | 4 | 0,750 | 1,500 | 0,500 | ● | ● | ● |  |  |
| Special ²⁾ | 2 | 1 | 2 | 0,7 | 4 | 0,750 | 1,350 | 0,450 | ● | ● | ● |  |  |
| | 2 | 1 | 4 | 0,7 | 4 | 0,750 | 1,200 | 0,400 | ● | ● | ● |  |  |

¹⁾ = Standard Contact Configuration
compatible with other manufacturers

²⁾ = Special Contact Configuration
not compatible with other manufacturers

* If you use a standard contact configuration, so please insert a "0".
If you use a special contact configuration, so please insert a "9".

1) Rated voltage acc. SAE AS 13441:1998 method 3001.1 corresponded MIL-STD 1344, method 3001, test acc. IEC 60512 test 4a. calculation method, caution and suggestion see page 80

2) The stamped crimp contacts are only with PEEK insulator available

Size 3, turned contacts

Part Number Key

| | | | | | | | | | | | | | | | | | | |
|---|---|---|---|---|---|---|---|---|----|----|----|----|----|----|----|----|----|----|
| 1 | 2 | 3 | 4 | 5 | 6 | 7 | 8 | 9 | 10 | 11 | 12 | 13 | 14 | 15 | 16 | 17 | 18 | 19 |
| | | 3 | | | | - | | | | | | | * | - | | | | |

* If you use a standard contact configuration, so please insert a "0".
If you use a special contact configuration, so please insert a "9".











| | Size | Positions | Positions | Contact Ø mm (Termination cross section see page 47) | Rated current (A) (Derating factor see page 54) | Test voltage acc. VDE 0627:1986:06 (kVrms) | Test voltage acc. SAE AS13441:1998 method 3001.1 (kVrms) | Rated voltage acc. SAE AS13441:1998 method 3001.1 (kVrms) ¹⁾ | Terminations (Surface see page 81) | | | View on to termination area | |
|---|------|-----------|-----------|---|--|---|---|--|---------------------------------------|---|---|-----------------------------|-------------|
| | | | | | | | | | Solder | Crimp (Tools for assembly see page 66) | PCB (PCB layout and pin length on request) | Pin Part | Socket part |
| Standard Contact Configuration <small>compatible with other manufacturers</small> | 3 | 1 | 5 | 0,9 | 10 | 1,000 | 1,650 | 0,550 | ● | ● | ● | | |
| | 3 | 2 | 4 | 0,7 | 7 | 1,000 | 1,200 | 0,400 | ● | ● | ● | | |
| | 3 | 2 | 7 | 0,7 | 7 | 1,000 | 1,200 | 0,400 | ● | ● | ● | | |
| Special Contact Configuration <small>not compatible with other manufacturers</small> | 3 | 0 | 4 | 2,0 | 22 | 1,500 | 1,500 | 0,500 | ● | ● | ● | | |
| | 3 | 0 | 7 | 1,6 | 17 | 1,250 | 1,800 | 0,600 | ● | ● | ● | | |
| | 3 | 0 | 8 | 1,3 | 14 | 1,250 | 1,650 | 0,550 | ● | ● | ● | | |
| | 3 | 1 | 4 | 0,9 | 10 | 1,250 | 1,350 | 0,450 | ● | ● | ● | | |
| | 3 | 1 | 8 | 0,9 | 10 | 1,000 | 1,350 | 0,450 | ● | ● | ● | | |
| | 3 | 2 | 0 | 0,7 | 7 | 1,000 | 1,100 | 0,366 | ● | ● | ● | | |
| | 3 | 2 | 2 | 0,7 | 7 | 0,875 | 1,100 | 0,366 | ● | ● | ● | | |
| | 3 | 2 | 6 | 0,7 | 7 | 0,875 | 1,000 | 0,333 | ● | ● | ● | | |

1) Rated voltage acc. SAE AS 13441:1998 method 3001.1 corresponded MIL-STD 1344, method 3001, test acc. IEC 60512 test 4a. calculation method, caution and suggestion see page 80

Size 3, stamped and formed contacts

Part Number Key

| | | | | | | | | | | | | | | | | | | |
|---|---|---|---|---|---|---|---|---|----|----|----|----|----|----|----|----|----|----|
| 1 | 2 | 3 | 4 | 5 | 6 | 7 | 8 | 9 | 10 | 11 | 12 | 13 | 14 | 15 | 16 | 17 | 18 | 19 |
| | | 3 | | | | - | | | | | | | * | - | | | | |

| | Size | Positions | | Contact Ø mm (Termination cross section see page 48) | Rated current (A) (Operating factor see page 54) | Test voltage acc. VDE 0627:1986-06 (kVrms) | Test voltage acc. SAE AS13441:1998 method 3001.1 (kVrms) | Rated voltage acc. SAE AS13441:1998 method 3001.1 (kVrms) ¹⁾ | Terminations (Surface see page 82) | | | View on to termination area | |
|------------------------|------|-----------|---|---|---|---|---|--|---------------------------------------|---|--|---|---|
| | | | | | | | | | Solder | Crimp (Tools for assembly see page 66) | PCB (only sockets) ²⁾ (PCB layout and pin length on request) | Pin Part | Socket part |
| Standard ^{1*} | 3 | 2 | 4 | 0,7 | 4 | 0,750 | 1,200 | 0,400 | ● | ● | ● |  |  |
| | 3 | 2 | 7 | 0,7 | 4 | 0,750 | 1,200 | 0,400 | ● | ● | ● |  |  |
| Special ^{2*} | 3 | 2 | 0 | 0,7 | 4 | 0,750 | 1,100 | 0,366 | ● | ● | ● |  |  |
| | 3 | 2 | 2 | 0,7 | 4 | 0,750 | 1,100 | 0,366 | ● | ● | ● |  |  |
| | 3 | 2 | 6 | 0,7 | 4 | 0,750 | 1,000 | 0,333 | ● | | |  |  |

^{1*} = Standard Contact Configuration
compatible with other manufacturers

^{2*} = Special Contact Configuration
not compatible with other manufacturers

* If you use a standard contact configuration, so please insert a "0".
If you use a special contact configuration, so please insert a "9".

1) Rated voltage acc. SAE AS 13441:1998 method 3001.1 corresponded MIL-STD 1344, method 3001, test acc. IEC 60512 test 4a. calculation method, caution and suggestion see page 80

2) The stamped crimp contacts are only with PEEK insulator available



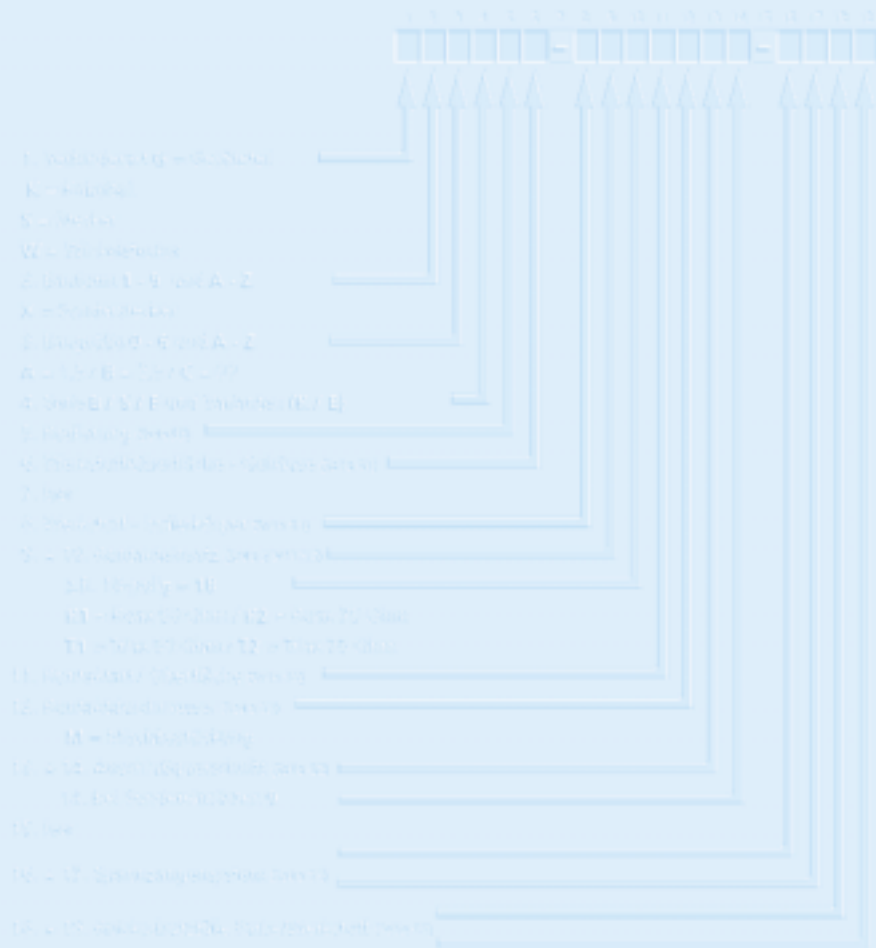

Details for the Part Number Key

- Coding System
- Housing Materials / Surfaces
- Insulation Body Material
- Contact Type / Surface / Diameter
- Contact Termination Cross Section (AWG)
- Collet System
- Bend Protection Sleeves

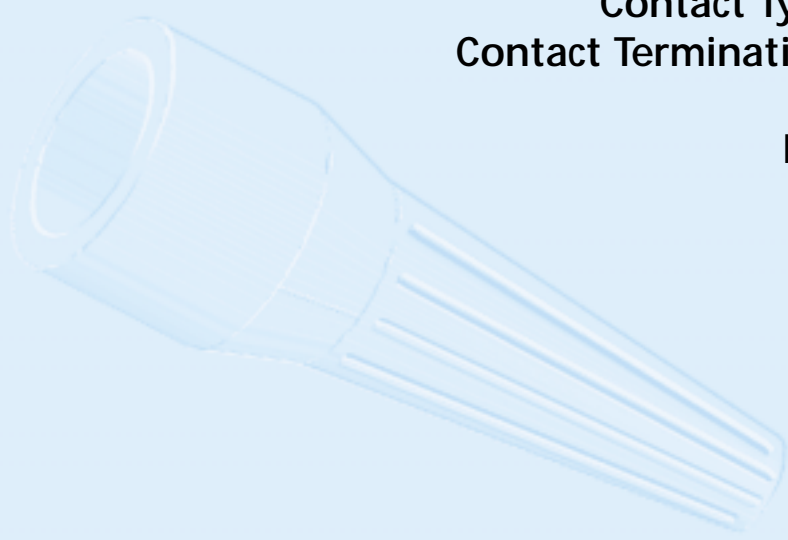

Coding

Part Number Key

| | | | | | | | | | | | | | | | | | | |
|---|---|---|---|---|---|---|---|---|----|----|----|----|----|----|----|----|----|----|
| 1 | 2 | 3 | 4 | 5 | 6 | 7 | 8 | 9 | 10 | 11 | 12 | 13 | 14 | 15 | 16 | 17 | 18 | 19 |
| | | | | | | - | | | | | | | | - | | | | |

| | Receptacle Front View | Size | | |
|--|-----------------------|------|---|---|
| | | 1 | 2 | 3 |
| 1 | | • | • | • |
| 2 | | • | | • |
| Special Coding (not compatible) | | | | |
| 9 | | • | | • |

Housing

Part Number Key

| | | | | | | | | | | | | | | | | | | |
|---|---|---|---|---|---|---|---|---|----|----|----|----|----|----|----|----|----|----|
| 1 | 2 | 3 | 4 | 5 | 6 | 7 | 8 | 9 | 10 | 11 | 12 | 13 | 14 | 15 | 16 | 17 | 18 | 19 |
| | | | | | | - | | | | | | | | - | | | | |

| | |
|---|---|
| 8 | Standard Plastic, black similar RAL 9004 |
| 3 | Plastic, white similar RAL 9002 (shielded version not in white colour available) |

Insulation Body Material

Part Number Key

| | | | | | | | | | | | | | | | | | | |
|---|---|---|---|---|---|---|---|---|----|----|----|----|----|----|----|----|----|----|
| 1 | 2 | 3 | 4 | 5 | 6 | 7 | 8 | 9 | 10 | 11 | 12 | 13 | 14 | 15 | 16 | 17 | 18 | 19 |
| | | | | | | - | | | | | | | | - | | | | |

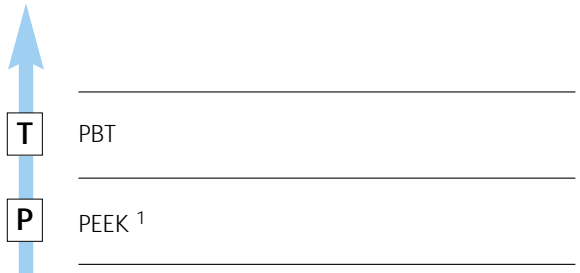

Turned Contacts

| | PBT | PEEK |
|--------|-----|------|
| Solder | ✓ | ✓ |
| Crimp | ✓ | - |
| Print | ✓ | ✓ |

Stamped and Formed Contacts

| | PBT | PEEK |
|--------|-----|------|
| Solder | ✓ | ✓ |
| Crimp | - | ✓ |
| Print | - | ✓ |

¹⁾ PEEK for receptacle disposable only on request.

Contact Type / Contact Surface - Contact Diameter

Part Number Key

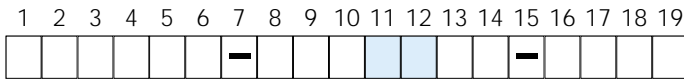

| | Type | Surface | | Contact Ø | |
|--------------------|--------|-----------------------|---|-----------|---|
| Turned Contacts | Socket | L - 0,75 µm Au (min.) | L | 0,50 | C |
| | Pin | L - 0,75 µm Au (min.) | M | 0,70 | F |
| | Socket | C - 0,75 µm Au (min.) | N | 0,90 | J |
| | Pin | C - 0,75 µm Au (min.) | P | mixed | M |
| | Socket | P - 0,75 µm Au (min.) | Q | 1,30 | P |
| | Pin | P - 0,75 µm Au (min.) | R | 1,50 | Q |
| * Stamped Contacts | Socket | L - 0,75 µm Au (min.) | 1 | 1,60 | S |
| | Pin | L - 0,75 µm Au (min.) | 2 | 2,00 | T |
| | Socket | C - 0,75 µm Au (min.) | 3 | 3,00 | V |
| | Pin | C - 0,75 µm Au (min.) | 4 | 4,00 | W |
| | Socket | P - 0,75 µm Au (min.) | 5 | | |

Has to mach with selected contact inserts (Page 35)

L = Solder termination

C = Crimp termination

P = PCB termination

* = Only with Ø 0,7 mm available

Termination Cross Section for Turned Contacts

Part Number Key

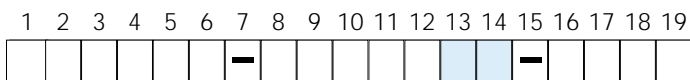

Crimp Contact

| Contact Ø | Size | AWG | mm ² |
|-----------|------|-------|-----------------|
| 0,7 | 1 | 24/26 | 0,25/0,15 |
| 0,7 | 1 | 22 | 0,38 |
| 0,9 | 1 | 24/26 | 0,25/0,15 |
| 0,9 | 1 | 20/22 | 0,50/0,38 |
| 1,3 | 1 | 18 | 1,0 |
| 0,7 | 2 | 24/26 | 0,25/0,15 |
| 0,7 | 2 | 22 | 0,38 |
| 0,9 | 2 | 24/26 | 0,25/0,15 |
| 0,9 | 2 | 22 | 0,38 |
| 0,9 | 2 | 20/22 | 0,50/0,38 |
| 1,3 | 2 | 18 | 1,0 |
| 0,7 | 3 | 24/26 | 0,25/0,15 |
| 0,7 | 3 | 22 | 0,38 |
| 0,7 | 3 | 28/30 | 0,08/0,05 |
| 0,9 | 3 | 24/26 | 0,25/0,15 |
| 0,9 | 3 | 20/22 | 0,50/0,38 |
| 1,3 | 3 | 18 | 1,0 |
| 1,6 | 3 | 16 | - |



| | |
|---|---|
| D | O |
| G | O |
| D | O |
| H | O |
| L | O |
| D | O |
| G | O |
| D | O |
| G | O |
| H | O |
| L | O |
| D | O |
| G | O |
| C | O |
| D | O |
| H | O |
| L | O |
| N | O |

Tools for crimping and their adjustments see Page 66

Solder Contact

| Contact Ø | Term. Ø | Term. Cross | |
|-----------|---------|-------------|-----------------|
| | | AWG | mm ² |
| 0,5 | 0,4 | 28 | 0,08 |
| 0,7 | 0,6 | 26 | 0,15 |
| 0,9 | 0,85 | 22 | 0,38 |
| 1,3 | 1,1 | 20 | 0,50 |
| 1,6 | 1,5 | 18 | 1,00 |
| 2,0 | 1,85 | 14 | 1,5 |
| 2,0 | 2,4 | | 2,5 |

| | |
|---|---|
| C | O |
| D | O |
| G | O |
| H | O |
| N | O |
| Q | O |
| S | O |

PCB Contact

| Contact Ø | Term. Ø |
|-----------|---------|
| 0,5 | 0,5 |
| 0,7 | 0,5 |
| 0,9 | 0,7 |
| 1,3 | 0,7 |
| 1,6 | 0,7 |
| 2,0 | 0,7 |

| | |
|---|---|
| O | O |
| O | O |
| O | O |
| O | O |
| O | O |
| O | O |

For mixed inserts

| | |
|---|---|
| O | O |
|---|---|

(Please provide details of termination cross section!)

Termination Cross Section for Stamped and Formed Contacts

Part Number Key

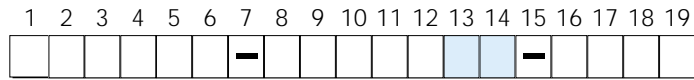

Crimp Contact

| Contact Ø | Size | AWG | mm ² |
|-----------|------|-------|-----------------|
| 0,7 | 1 | 24/22 | 0,22/0,38 |
| 0,7 | 1 | 28/26 | 0,09/0,14 |
| 0,7 | 2 | 24/22 | 0,22/0,38 |
| 0,7 | 2 | 28/26 | 0,09/0,14 |
| 0,7 | 3 | 24/22 | 0,22/0,38 |
| 0,7 | 3 | 28/26 | 0,09/0,14 |



| | |
|---|---|
| Y | 0 |
| Z | 0 |
| Y | 0 |
| Z | 0 |
| Y | 0 |
| Z | 0 |

Solder Contact

| Contact Ø | Term. Ø | Term. Cross | |
|-----------|---------|-------------|-----------------|
| | | AWG | mm ² |
| 0,7 | 1,0 | 22 | 0,38 |

| | |
|---|---|
| G | 0 |
|---|---|

PCB Contact*

| Contact Ø | Term. Ø |
|-----------|---------|
| 0,7 | 0,7 |

| | |
|---|---|
| 0 | 0 |
|---|---|

* Only socket insert available

Plastic cable collet for the Types B & D (Page 32 and 34)

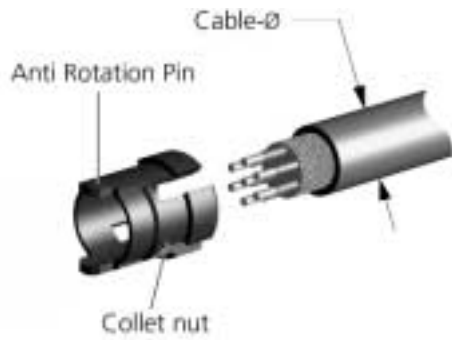

Part Number Key

| | | | | | | | | | | | | | | | | | | |
|---|---|---|---|---|---|---|---|---|----|----|----|----|----|----|----|----|----|----|
| 1 | 2 | 3 | 4 | 5 | 6 | 7 | 8 | 9 | 10 | 11 | 12 | 13 | 14 | 15 | 16 | 17 | 18 | 19 |
| | | | | | | - | | | | | | | | - | | | | |

Insert: for all Plugs and In-Line Receptacles of the Types B & D

Application: **Collet Nut** for strain relief.

| Cable diameter in mm | Size | | |
|----------------------|------|---|---|
| | 1 | 2 | 3 |
| > 1,5 - 3,0 | ● | | |
| > 3,1 - 4,5 | ● | ● | |
| > 4,6 - 6,0 | ● | ● | ● |
| > 6,1 - 7,5 | | ● | ● |
| > 7,6 - 9,0 | | ● | ● |
| > 9,1 - 10,5 | | | ● |
| without collet nut | | | |
| with all collet nuts | | | |

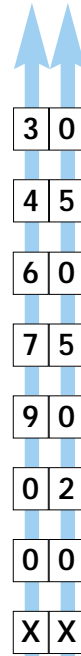

| | |
|---|---|
| 3 | 0 |
| 4 | 5 |
| 6 | 0 |
| 7 | 5 |
| 9 | 0 |
| 0 | 2 |
| 0 | 0 |
| X | X |

Collet System for the Types A & C (Page 32)

Part Number Key

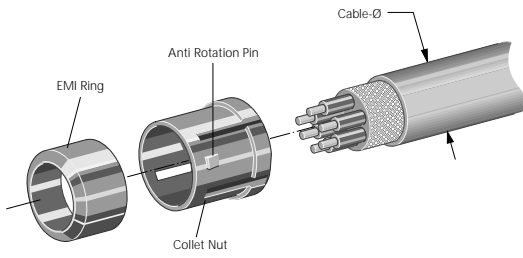

| | | | | | | | | | | | | | | | | | | |
|---|---|---|---|---|---|---|---|---|----|----|----|----|----|----|----|----|----|----|
| 1 | 2 | 3 | 4 | 5 | 6 | 7 | 8 | 9 | 10 | 11 | 12 | 13 | 14 | 15 | 16 | 17 | 18 | 19 |
| | | | | | | - | | | | | | | | - | | | | |

Insert: for all Plugs and In-Line Receptacles of the Types A & C.

Application: **Collet nut** for strain relief, **EMI ring** for conductive path between shield and housing.

| Cable diameter in mm | Size | | |
|-----------------------|------|---|---|
| | 1 | 2 | 3 |
| > 2,5 - 3,0 | ● | ● | |
| > 3,0 - 3,5 | ● | ● | ● |
| > 3,5 - 4,0 | ● | ● | ● |
| > 4,0 - 4,5 | ● | ● | ● |
| > 4,5 - 5,0 | ● | ● | ● |
| > 5,0 - 5,5 | ● | ● | ● |
| > 5,5 - 6,0 | ● | ● | ● |
| > 6,0 - 6,5 | ● | ● | ● |
| > 6,5 - 7,0 | ● | ● | ● |
| > 7,0 - 7,5 | | ● | ● |
| > 7,5 - 8,0 | | ● | ● |
| > 8,0 - 8,5 | | ● | ● |
| > 8,5 - 9,0 | | ● | ● |
| > 9,0 - 9,5 | | | ● |
| > 9,5 - 10,0 | | | ● |
| > 10,0 - 10,5 | | | ● |
| > 10,5 - 11,0 | | | ● |
| without collet system | | | |

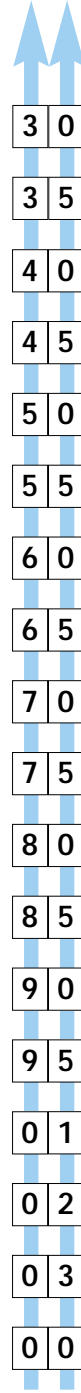

**Right-angled PCB-contacts for the Receptacle
Part Number Key**

| 1 | 2 | 3 | 4 | 5 | 6 | 7 | 8 | 9 | 10 | 11 | 12 | 13 | 14 | 15 | 16 | 17 | 18 | 19 | |
|---|---|---|---|---|---|---|---|---|----|----|----|----|----|----|----|----|----|----|--|
| G | 5 | | | | | - | | | | | | | | - | | | | | |

Right-angled PCB-contacts



Only in **style 5** available.
Style 1 and E on request.

For the Panel cut-out and
the PCB-layout please
ask for a data sheet.

Cable Bend Relief

(see page 62)

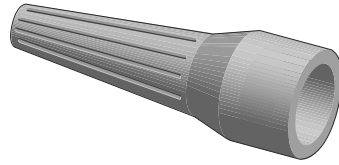

Part Number Key

| | | | | | | | | | | | | | | | | | | |
|---|---|---|---|---|---|---|---|---|----|----|----|----|----|----|----|----|----|----|
| 1 | 2 | 3 | 4 | 5 | 6 | 7 | 8 | 9 | 10 | 11 | 12 | 13 | 14 | 15 | 16 | 17 | 18 | 19 |
| | | | | | | - | | | | | | | | - | | | | |

Color of the Cable Bend Relief

| Color / RAL-Number <small>(similar)</small> | |
|--|----------|
| red | RAL 3020 |
| white | RAL 9010 |
| yellow | RAL 1016 |
| green | RAL 6029 |
| blue | RAL 5002 |
| grey | RAL 7005 |
| black | RAL 9005 |
| orange | RAL 2004 |
| purple | RAL 4005 |
| brown | RAL 8016 |
| light green | RAL 6018 |
| light blue | RAL 5012 |
| Material | |
| PUR | |
| without cable bend relief | |



Temperature range
 PUR -40 °C up to +80 °C
 Short-term up to +120 °C

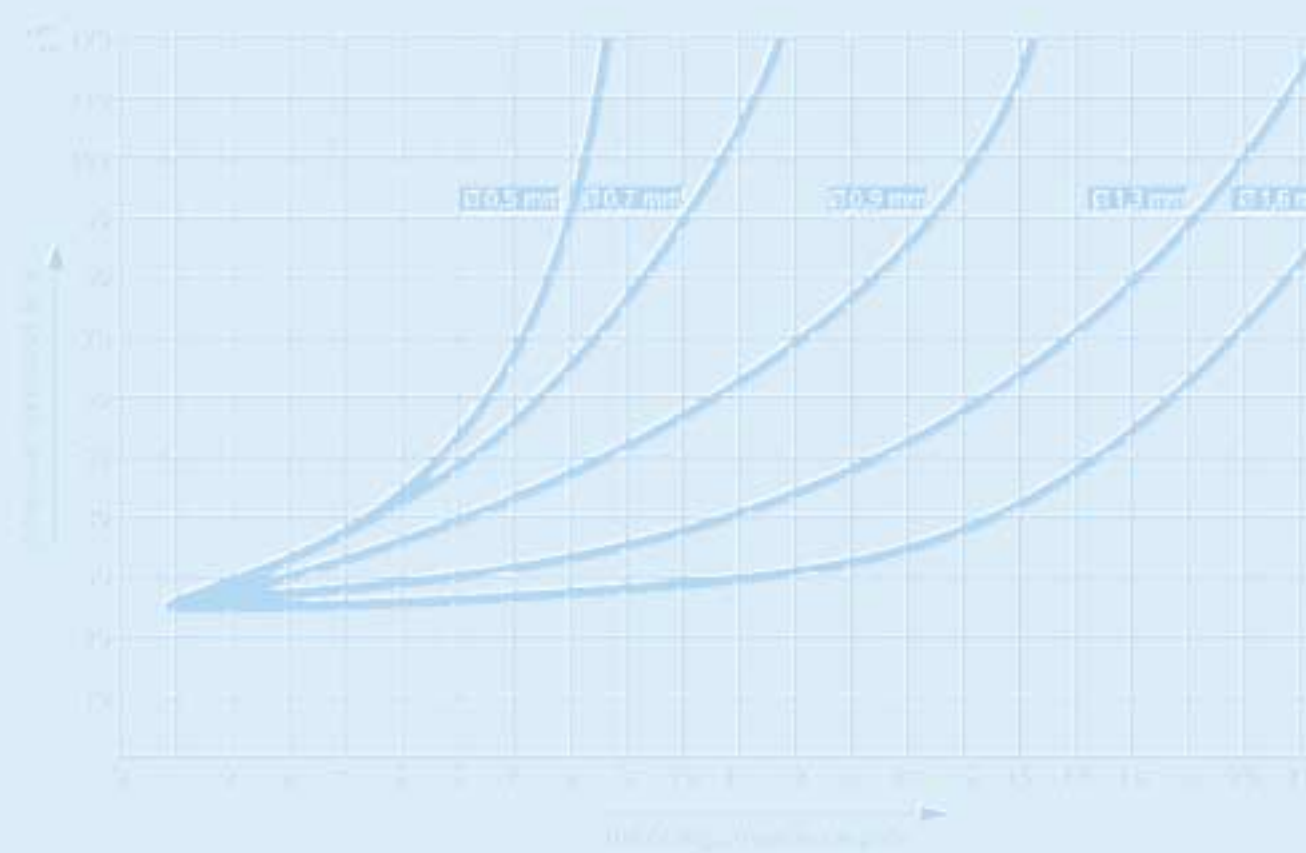

Technical Informations for the ODU MINI-SNAP PC

Current Load - Turned Contacts

Nominal Single Contact Current Load for pin / slotted socket

(Nominal Diameter 0.5 mm - 1.6 mm)

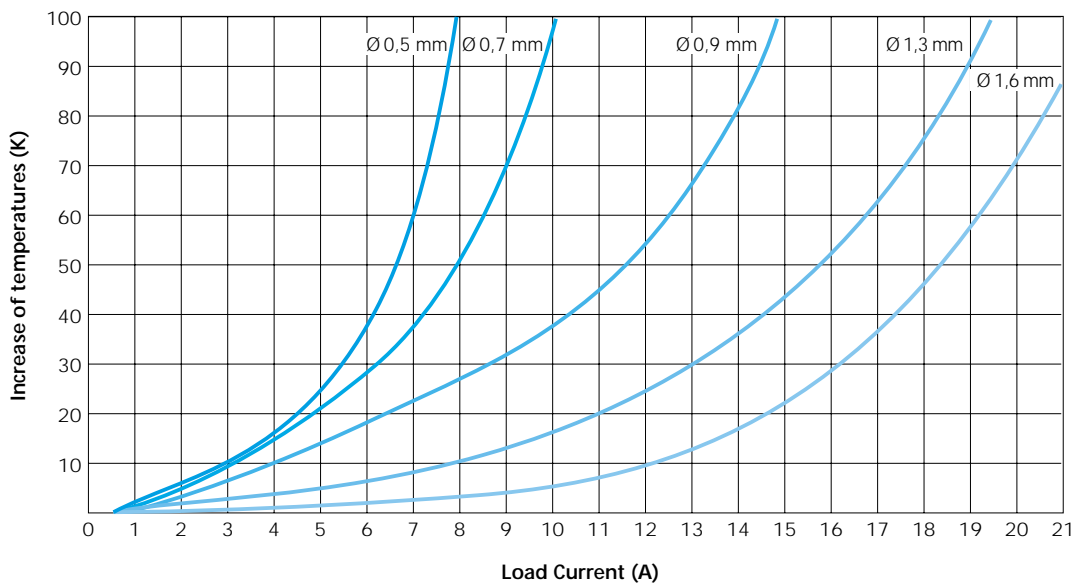

➔ **Upper Maximum Temperature for Standard Contacts:** + 120 °C

Test contact was terminated to largest possible conductor.

Connectors or cables with more than one contact or conductor generate a higher temperature than a single contact. Therefore, a **Derating Factor** must be applied. For connectors the Derating Factor is applied according to DIN 57 298 part 2 / VDE 0298 part 2. The Derating Factor is used starting with 5 loaded wires. (DIN 41 640 T 3)

Derating Factor:

| Number of loaded wires | Derating Factor |
|------------------------|-----------------|
| 5 | 0,75 |
| 7 | 0,65 |
| 10 | 0,55 |
| 14 | 0,50 |
| 19 | 0,45 |
| 24 | 0,40 |

Current Load - Stamped and Formed Contacts

Nominal Single Contact Current Load for pin / slotted socket

(Nominal diameter 0,7 mm)

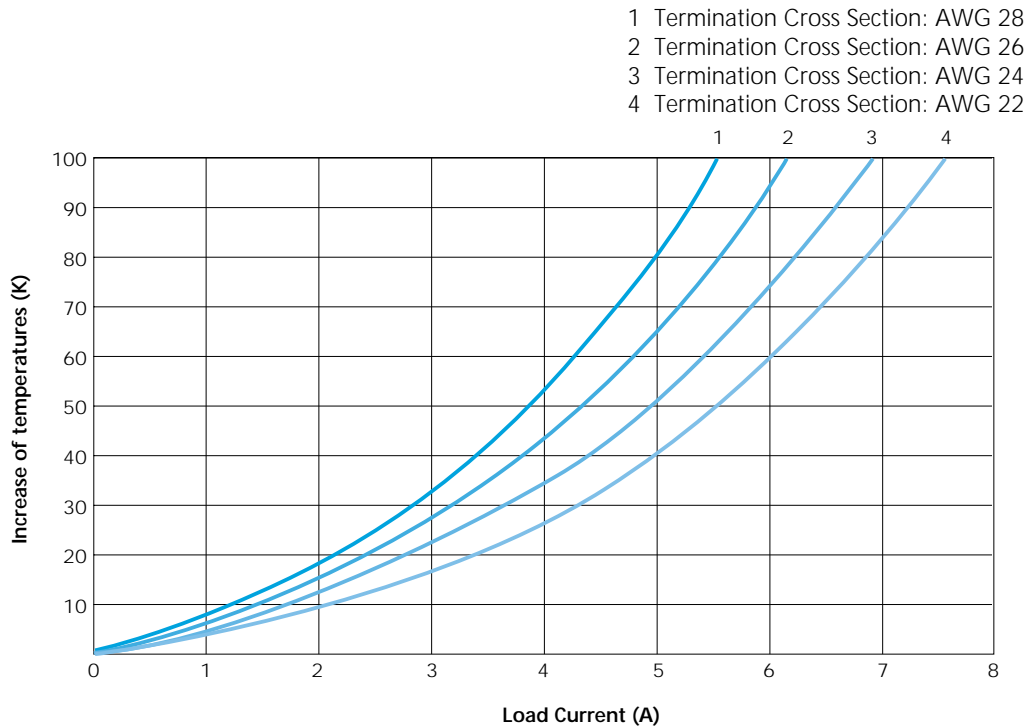

Mating Force: ... ~ 0,35... N

Demating Force: ... ~ 0,33... N

Conclusion: The diagram shows that the connector under a current load of 4 A will reach a temperature of approx. 54 K with connection AWG 28 will reach a temperature of approx. 44 K with connection AWG 26 will reach a temperature of approx. 34 K with connection AWG 24 will reach a temperature of approx. 27 K with connection AWG 22

Housing materials / Surfaces

| | Material | Surface |
|---|-----------------------------|---|
| Component Parts | Designation | Thickness of the film |
| Housing (standard) Back Nut Sleeve | → PEI (GF) Polyetherimid | - |
| Housing (shielded) | → PEI (GF) Polyetherimid | Partial: + 5 µm Cu + 2 µm Ni |
| Collet (Type B & D) | → PES Polyethersulfon | - |
| Collet (Type A & C) EMI-Ring Half-Shells Nut | → Cu-alloy | → Ni matt 6-8 µm |
| Turned Contacts | → Cu-alloy | → + 1,25 µm Ni + 0,75 µm Au |
| Stamped and formed contacts | → Cu-alloy | → + 1,25 µm Ni + 0,75 µm Au on the mating area + 3,00 µm Sn on the termination area |

Insulation Body Material (UL 94 V-0 rated)

| | Norm | | Unit | PBT | PEEK |
|--------------------------------------|-----------|------------|---------|--------------|------------|
| Dialectric Strenght | DIN 53481 | ASTM D-149 | KV / mm | 30 | 19 |
| Operating Temperature | -- | -- | °C | - 40 / + 140 | -50 / +250 |
| Flammability rating | UL-94 | -- | -- | V-0 | V-0 |
| Creeping distance acc. to CTI | IEC 60112 | | (V) | 275 | 175 |

Mating Force, Demating Force and Pull-Off-Force

(All details are for the standard housing without insert)

| | Size 1 | Size 2 | Size 3 |
|------------------------|------------|------------|------------|
| Mating Force | max. 2,5 N | max. 2,8 N | max. 3 N |
| Demating Force | max. 2,6 N | max. 2,8 N | max. 3 N |
| Pull-Off-Force* | min. 80 N | min. 80 N | min.. 85 N |

* After an inadvertent pull-out the plug can be used again.

Electromagnetic Compatibility (EMC)

When discussing electromagnetic compatibility (EMC) we need take into account not only the device, circuit etc. but moreover the entire network and communication links and interconnections. This involves all connecting elements such as conductors and connectors. Electromagnetic interference from the outside into the connector can lead to system malfunctioning. The best way to prevent this is by providing a high-quality shield between the cable and the connector. In order to provide reliable EMC data to our customers we engaged the services of a certified test laboratory to investigate the EMC characteristics of the ODU MINI-SNAP PC. They tested for us Size 00, 0, 1, 2 and 3 MINI-SNAP connectors.

Measurements were conducted using the inductive wire or parallel wire method in accordance with test procedure VG 55214-6-2. In this set-up, the mated connector is connected on one end to a network analyzer and terminated on the other end with a suitable impedance. The inductive wire is then mounted in close proximity along the mated connector pair. The induction wire is a ribbon cable which permits to vary the level of induction by using more or less of the ribbon conductors.

Next, a signal with a frequency range of 100 kHz to 2,5 GHz is connected to the ribbon cable. The network analyzer is used to measure the amount of signal induced into the connector circuit. The result is shown as the shielding attenuation A_T in dB. It is essential that all leads to the connector are shielded so that no signal can be induced into the circuit at any other place except the connector. The various attenuation values are plotted on a logarithmic scale as attenuation in dB vs. frequency.

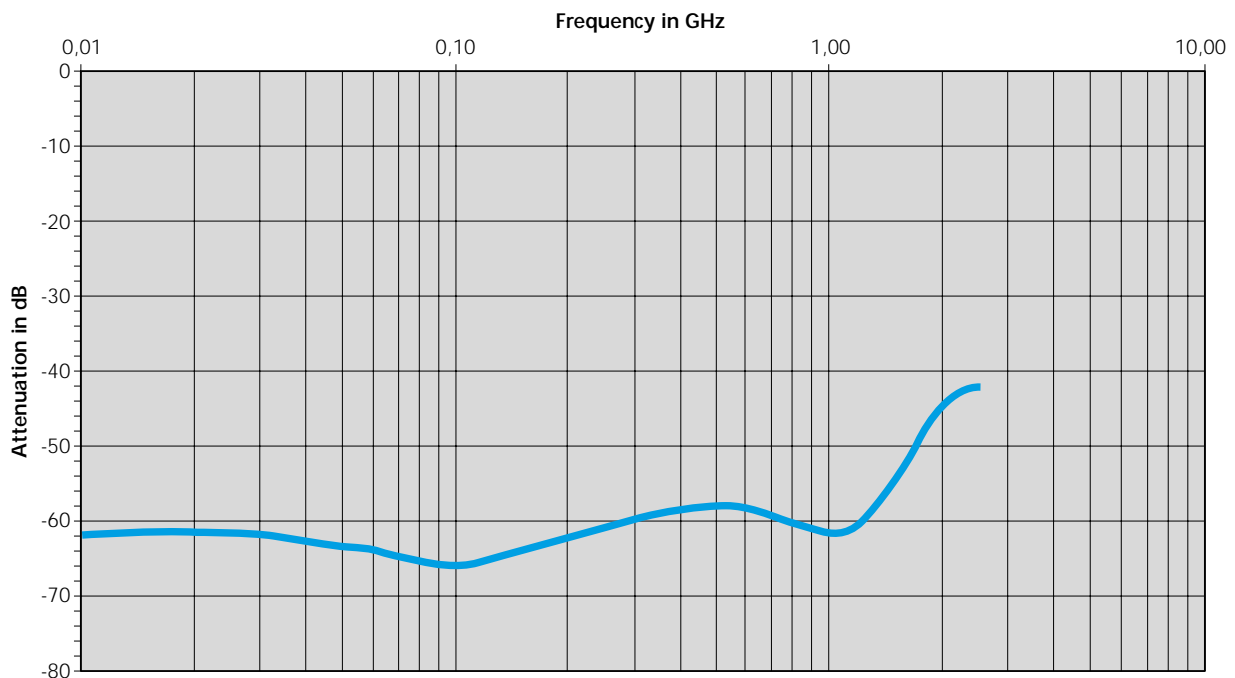
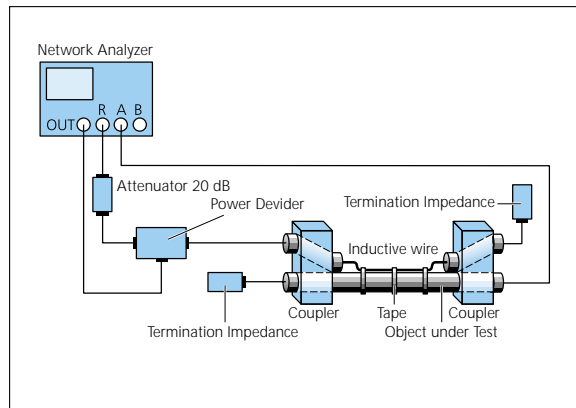

Autoclaving of ODU MINI-SNAP Connectors

If required ODU can deliver MINI-SNAP connectors for the following sterilization process:
 Steam-sterilization with pre-vacuum or gravitation-process. Connectors were tested with autoclave equipment with reference to DIN EN 13 060 at 134° C and 200 cycles.

Sterilization Curve:

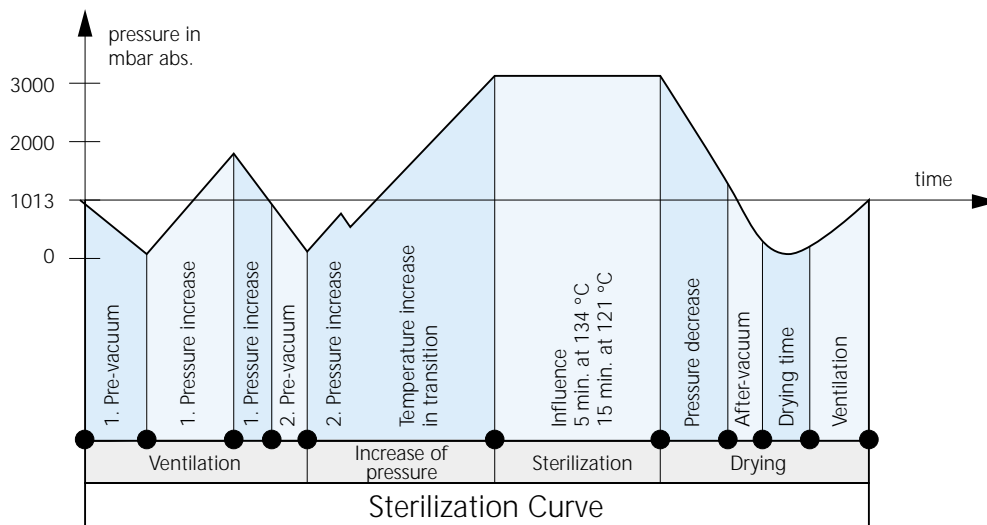

For other sterilization-processes please contact our technical support team.



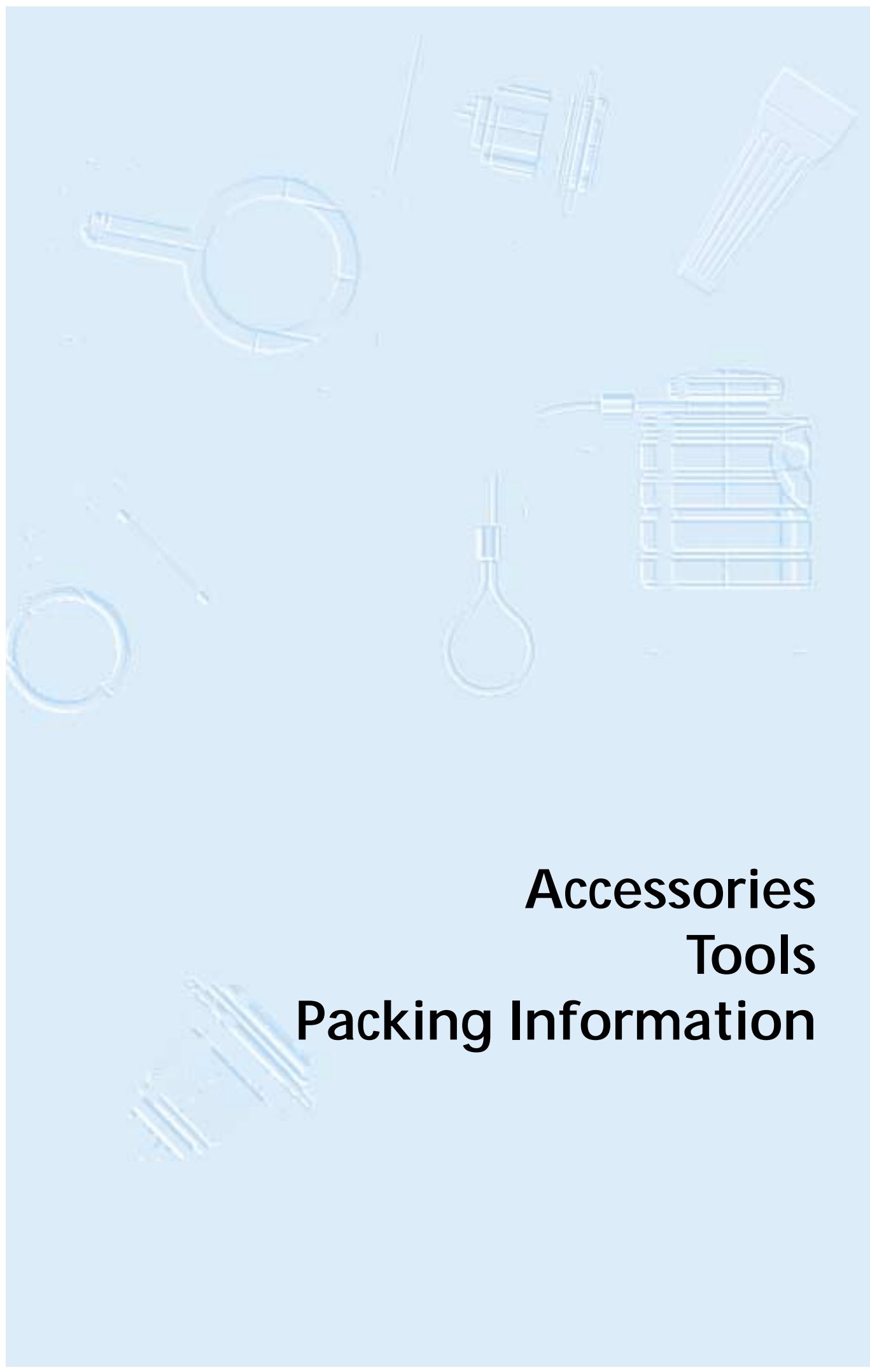

Accessories Tools Packing Information

Back Nut for Cable Bend Relief

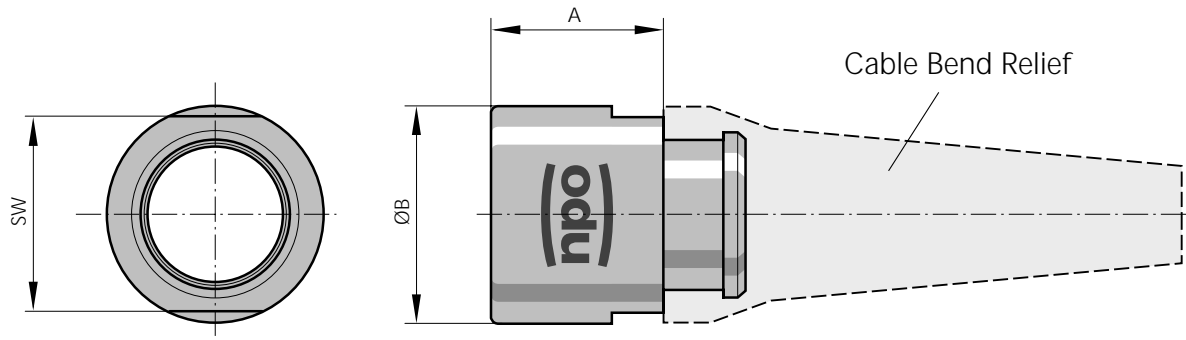

| Color | Size | Part Number | Dimensions in mm | | |
|-------|------|---------------------|------------------|------|------|
| | | | A | ØB | SW |
| Black | 1 | K01 020 113 937 028 | 10,0 | 11,0 | 10,0 |
| | 2 | K02 020 113 937 028 | 11,5 | 14,0 | 13,0 |
| | 3 | K03 020 113 937 028 | 11,5 | 17,0 | 15,0 |
| White | 1 | K01 020 113 937 023 | 10,0 | 11,0 | 10,0 |
| | 2 | K02 020 113 937 023 | 11,5 | 14,0 | 13,0 |
| | 3 | K03 020 113 937 023 | 11,5 | 17,0 | 15,0 |

Cable Bend Relief

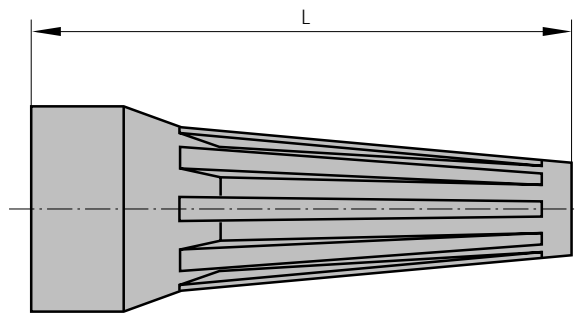

* = In ... please indicate color code

| Size | Part Number* | Dim. L | Cable O.D. | |
|------|---------------------|--------|------------|------|
| | | | min. | max. |
| 1 | 701 022 ... 960 025 | 30 | > 2,5 | 3,0 |
| 1 | 701 022 ... 960 030 | 30 | > 3,0 | 3,5 |
| 1 | 701 022 ... 960 035 | 30 | > 3,5 | 4,0 |
| 1 | 701 022 ... 960 040 | 30 | > 4,0 | 5,0 |
| 1 | 701 022 ... 960 050 | 30 | > 5,0 | 6,0 |
| 1 | 701 022 ... 960 060 | 30 | > 6,0 | 6,5 |
| 1 | 701 022 ... 960 070 | 30 | > 6,5 | 7,5 |
| 2 | 702 022 ... 960 030 | 36 | > 3,0 | 3,5 |
| 2 | 702 022 ... 960 035 | 36 | > 3,5 | 4,0 |
| 2 | 702 022 ... 960 040 | 36 | > 4,0 | 5,0 |
| 2 | 702 022 ... 960 050 | 36 | > 5,0 | 6,0 |
| 2 | 702 022 ... 960 060 | 36 | > 6,0 | 7,0 |
| 2 | 702 022 ... 960 070 | 36 | > 7,0 | 8,0 |
| 2 | 702 022 ... 960 080 | 36 | > 8,0 | 9,0 |
| 3 | 703 022 ... 960 040 | 42 | > 4,0 | 5,0 |
| 3 | 703 022 ... 960 050 | 42 | > 5,0 | 6,0 |
| 3 | 703 022 ... 960 060 | 42 | > 6,0 | 7,0 |
| 3 | 703 022 ... 960 070 | 42 | > 7,0 | 8,0 |
| 3 | 703 022 ... 960 080 | 42 | > 8,0 | 9,0 |
| 3 | 703 022 ... 960 090 | 42 | > 9,0 | 10,0 |

| Color code | Color | RAL-No. (similar) |
|------------|-------------|-------------------|
| 202 | red | 3020 |
| 203 | white | 9010 |
| 204 | yellow | 1016 |
| 205 | green | 6029 |
| 206 | blue | 5002 |
| 207 | grey | 7005 |
| 208 | black | 9005 |
| 209 | orange | 2004 |
| 210 | violet | 4005 |
| 212 | brown | 8016 |
| 215 | light green | 6018 |
| 216 | light blue | 5012 |

Temperature range

PUR -40 °C up to +80 °C
Short-term up to +120 °C

Protective Cover for IP50 and IP68 (for all receptacle styles)

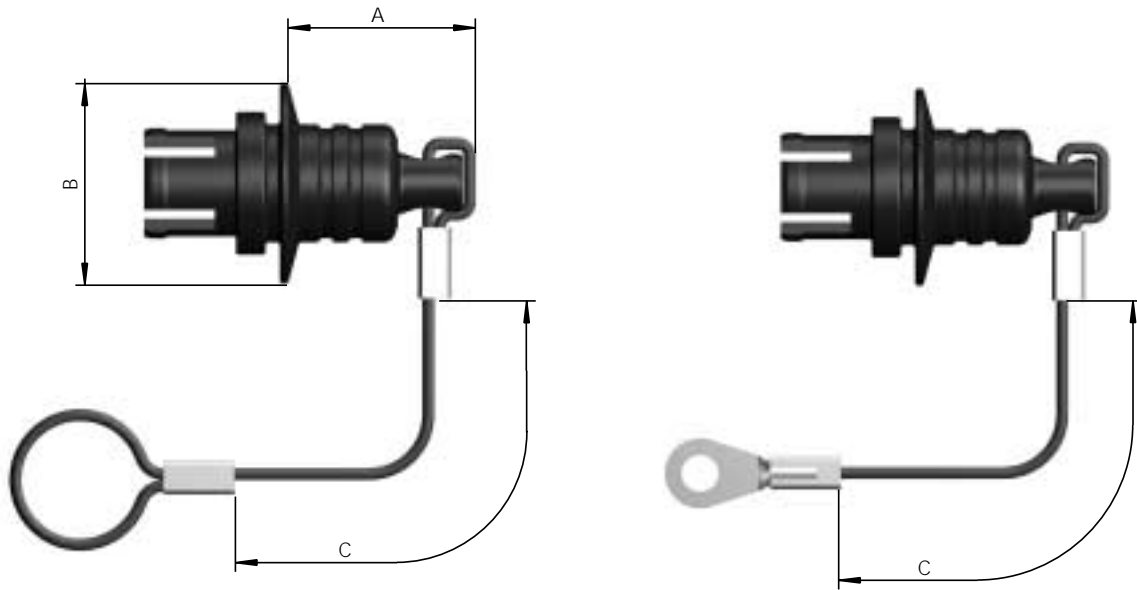

| Size | Part Number | Dimensions in mm | | |
|------|---------------------|------------------|------|------|
| | | A | B | C |
| 1 | K01 097 006 933 .0. | 15,1 | 17 | ~75 |
| 2 | K02 097 006 933 .0. | 11,5 | 14,0 | ~85 |
| 3 | K03 097 006 933 .0. | 11,5 | 17,0 | ~100 |

With . please, register desired lanyard material
 0 = Polyamid lanyard with loop
 1 = Stainless steel lanyard with loop
 2 = Polyamid lanyard with solder lug
 3 = Stainless steel lanyard with solder lug

With . please, register desired colour of the cap*
 3 = White cap
 8 = Black cap

* = If you use a polyamid lanyard, the colour is corresponding with the colour of the cap.

Spanner Wrench

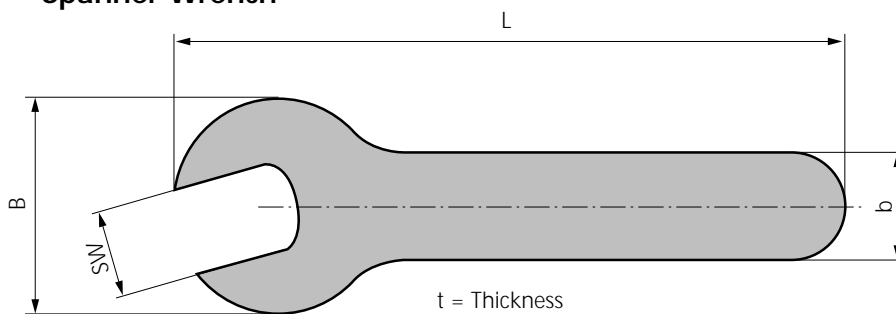

| Part number | No. | SW | t | B | L | b |
|---------------------|-----|----|-----|------|-----|------|
| 598.700.001.012.000 | 11 | 11 | 2 | 24,5 | 115 | 10 |
| 598.700.001.004.000 | 13 | 13 | 2,5 | 30,5 | 98 | 16,5 |
| 598.700.001.007.000 | 16 | 16 | 3 | 35,5 | 145 | 15 |
| 598.700.001.008.000 | 17 | 17 | 3 | 35,5 | 145 | 15 |
| 598.700.001.013.000 | 19 | 19 | 3 | 40,0 | 100 | 18 |
| 598.700.001.014.000 | 24 | 24 | 3 | 54,0 | 215 | 22 |



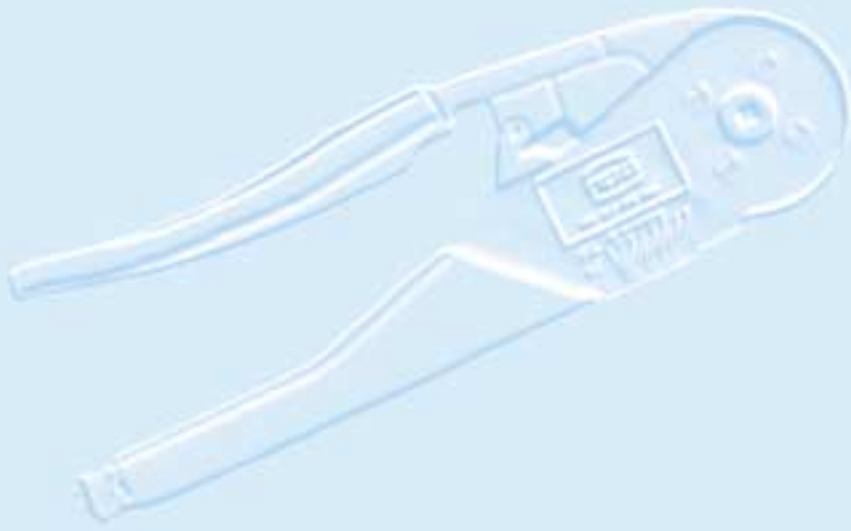

Tools

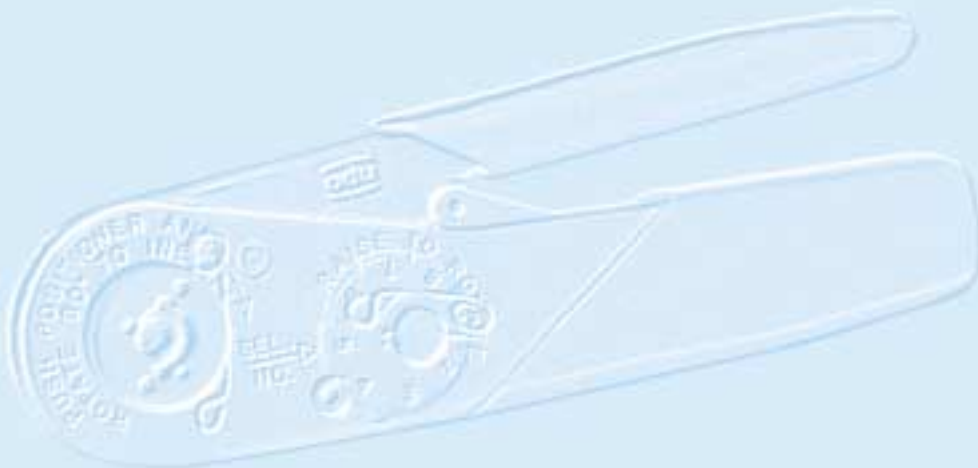

Crimping Tongs and Assembling Tools for Turned Contacts

1. The 037 and 038 Tongs

These both 8-point-crimptongs are new in the catalogue. They will be the standard version in the future.

The 037 Tong



Order number: 080.000.037.000.000
Suitable for our Crimp Contacts with diameter **0,7 – 0,9 mm**.

The 038 Tong

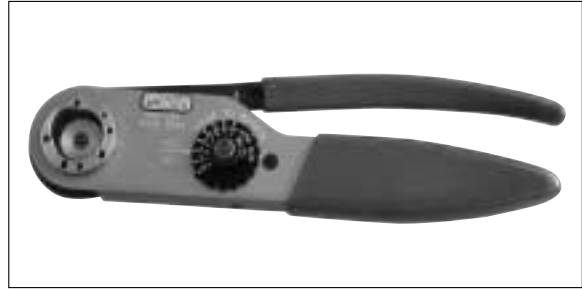

Order number: 080.000.038.000.000
Suitable for our Crimp Contacts with diameter **1,3 – 1,6 mm**.

These both tongs will replace in the early future our 014 tong below. The advantages of these tongs are the easy handling and of course the very good price. All order informations for the equipment of these tongs you can find on page 67.

2. The 014 Tong

This is the precursor version of the above shown tongs. Also here is a 8-point-crimp the result.

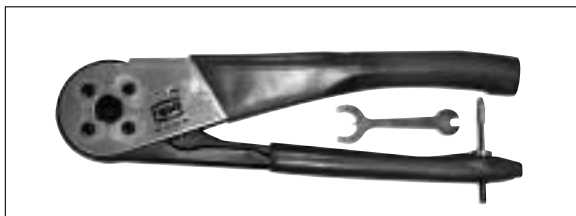

Order number: 080.000.014.000.000

Suitable for all available diameters of our ODU MINI-SNAP Crimp Contacts. All order informations for the equipment of these tongs you can find on page 68

3. The 032 Tong

This 032 Tong is a pneumatic 8-point-crimptool. Please contact our Sales Team for Datasheets about this tong

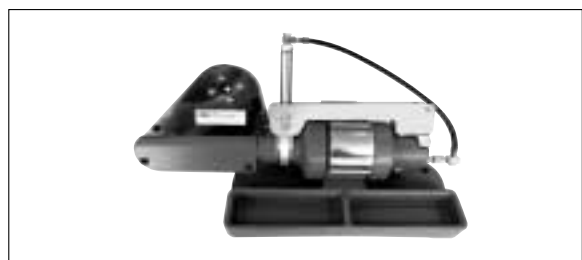

Assembly Jig for the assembling of our Crimp Contacts into the insulation body (see page 71)



| Size | Part number |
|------|---------------------|
| 0 | 700.098.004.300.000 |
| 1 | 701.098.004.300.000 |
| 2 | 702.098.004.300.000 |
| 3 | 703.098.004.300.000 |
| 4 | 704.098.004.300.000 |
| 5 | 705.098.004.300.000 |

Assembly Tools for Turned Contacts for Crimping Tools 037 and 038

Standard Contact Configuration

| Position | Size | AWG | mm ² | Adjustments for Crimp Tool 080.000.037.000.000 | Adjustment for Crimp Tool 080.000.038.000.000 | Positionier | | Insertion Tool |
|----------|------|-------------|-------------------|--|---|---------------------|---------------------|---------------------|
| | | | | | | for Socket Contact | for Pin Contact | |
| 3 | 1 | 18 | 1.0 | - | 5 | 081 701 001 744 038 | 081 701 001 844 038 | 085 180 955 000 000 |
| 4 | 1 | 24/26 22 | 0.25/0.15 0.38 | 4 7 | - | 081 701 001 749 037 | 081 702 001 849 037 | 085 180 689 000 000 |
| 5 | 1 | 24/26 22 | 0.25/0.15 0.38 | 4 7 | - | 081 701 001 749 037 | 081 702 001 849 037 | 085 180 689 000 000 |
| 6 | 1 | 24/26 22 | 0.25/0.15 0.38 | 4 4 | - | 081 701 002 748 037 | 081 701 002 848 037 | 085 180 676 000 000 |
| 7 | 1 | 24/26 22 | 0.25/0.15 0.38 | 4 4 | - | 081 701 002 748 037 | 081 701 002 848 037 | 085 180 676 000 000 |
| 6 | 2 | 24/26 22 | 0.25/0.15 0.38 | 4 7 | - | 081 702 001 749 037 | 081 702 001 849 037 | 085 180 689 000 000 |
| 11 | 2 | 24/26 22 | 0.25/0.15 0.38 | 4 7 | - | 081 702 001 749 037 | 081 702 001 849 037 | 085 180 689 000 000 |
| 16 | 2 | 24/26 22 | 0.25/0.15 0.38 | 4 4 | - | 081 702 002 748 037 | 081 702 002 848 037 | 085 180 677 000 000 |
| 19 | 2 | 24/26 22 | 0.25/0.15 0.38 | 4 4 | - | 081 702 002 748 037 | 081 702 002 848 037 | 085 180 677 000 000 |
| 15 | 3 | 24/26 22 | 0.25/0.15 0.38 | 4 7 | - | 081 702 001 749 037 | 081 703 001 849 037 | 085 180 689 000 000 |
| 24 | 3 | 24/26 22 | 0.25/0.15 0.38 | 4 4 | - | 081 703 003 748 037 | 081 702 002 848 037 | 085 180 677 000 000 |
| 27 | 3 | 24/26 22 | 0.25/0.15 0.38 | 4 4 | - | 081 703 003 748 037 | 081 702 002 848 037 | 085 180 677 000 000 |

Special Contact Configuration

| Position | Size | AWG | mm ² | Adjustments for Crimp Tool 080.000.037.000.000 | Adjustment for Crimp Tool 080.000.038.000.000 | Positionier | | Insertion Tool |
|----------|------|-------------|-------------------|--|---|---------------------|---------------------|---------------------|
| | | | | | | for Socket Contact | for Pin Contact | |
| 8 | 1 | 24/26 22 | 0.25/0.15 0.38 | 4 4 | - | 081 701 001 748 037 | 081 701 002 848 037 | 085 180 677 000 000 |
| 3 | 2 | 18 | 1.0 | - | 5 | 081 702 001 744 038 | 081 702 001 844 038 | 085 180 955 000 000 |
| 6 | 2 | 18 | 1.0 | - | 5 | 081 702 001 744 038 | 081 702 001 844 038 | 085 180 955 000 000 |
| 8 | 2 | 24/26 22 | 0.25/0.15 0.38 | 4 7 | - | 081 702 001 749 037 | 081 702 001 849 037 | 085 180 691 000 000 |
| 10 | 2 | 24/26 22 | 0.25/0.15 0.38 | 4 7 | - | 081 702 001 749 037 | 081 702 001 849 037 | 085 180 691 000 000 |
| 12 | 2 | 24/26 22 | 0.25/0.15 0.38 | 4 4 | - | 081 702 001 748 037 | 081 702 001 848 037 | 085 180 676 000 000 |
| 7 | 3 | 16 | 16 | - | - | 081 703 001 751 038 | 081 703 001 851 038 | 085 182 707 000 000 |
| 8 | 3 | 22 18 | 0.38 1.0 | - - | 2 5 | 081 703 001 744 038 | 081 703 001 844 038 | 085 180 955 000 000 |
| 14 | 3 | 24/26 22 | 0.25/0.15 0.38 | 4 7 | - | 081 703 001 749 037 | 081 703 001 849 037 | 085 180 689 000 000 |
| 18 | 3 | 24/26 22 | 0.25/0.15 0.38 | 4 7 | - | 081 703 001 749 037 | 081 703 001 849 037 | 085 180 689 000 000 |
| 20 | 3 | 24/26 22 | 0.25/0.15 0.38 | 4 4 | - | 081 703 002 748 037 | 081 702 001 848 037 | 085 180 676 000 000 |
| 22 | 3 | 24/26 22 | 0.25/0.15 0.38 | 4 4 | - | 081 703 003 748 037 | 081 702 002 848 037 | 085 180 677 000 000 |
| 26 | 3 | 24/26 22 | 0.25/0.15 0.38 | 4 4 | - | 081 703 003 748 037 | 081 702 002 848 037 | 085 180 677 000 000 |



Assembly Tools for Turned Contacts for Crimping Tool 014

Standard Contact Configuration

| Position | Size | AWG | mm ² | Adjustments for Crimp Tool 080.000.014.000.000 | Positionier for Socket and/or Pin Contact | Gauge Pin (for Adjustment) | | Insertion Tool |
|----------|------|-------------|-------------------|---|--|--|--|---------------------|
| | | | | | | minimum | maximum | |
| 3 | 1 | 18 | 1.0 | > 1.10 < 1.15 | 021 345 189 300 000 | 080 000 014 000 110 | 080 000 014 000 115 | 085 180 955 000 000 |
| 4 | 1 | 24/26 22 | 0.25/0.15 0.38 | > 0.65 < 0.70 > 0.90 < 0.95 | 021 345 192 300 000 | 080 000 014 000 065 080 000 014 000 090 | 080 000 014 000 070 080 000 014 000 095 | 085 180 689 000 000 |
| 5 | 1 | 24/26 22 | 0.25/0.15 0.38 | > 0.65 < 0.70 > 0.90 < 0.95 | 021 345 192 300 000 | 080 000 014 000 065 080 000 014 000 090 | 080 000 014 000 070 080 000 014 000 095 | 085 180 689 000 000 |
| 6 | 1 | 24/26 22 | 0.25/0.15 0.38 | > 0.65 < 0.70 > 0.65 < 0.70 | 021 345 175 300 | 080 000 014 000 065 | 080 000 014 000 070 | 085 180 676 000 000 |
| 7 | 1 | 24/26 22 | 0.25/0.15 0.38 | > 0.65 < 0.70 > 0.65 < 0.70 | 021 345 175 300 | 080 000 014 000 065 | 080 000 014 000 070 | 085 180 676 000 000 |
| 6 | 2 | 24/26 22 | 0.25/0.15 0.38 | > 0.65 < 0.70 > 0.90 < 0.95 | 021 345 174 300 000 | 080 000 014 000 065 080 000 014 000 090 | 080 000 014 000 070 080 000 014 000 095 | 085 180 689 000 000 |
| 11 | 2 | 24/26 22 | 0.25/0.15 0.38 | > 0.65 < 0.70 > 0.90 < 0.95 | 021 345 174 300 000 | 080 000 014 000 065 080 000 014 000 090 | 080 000 014 000 070 080 000 014 000 095 | 085 180 689 000 000 |
| 16 | 2 | 24/26 22 | 0.25/0.15 0.38 | > 0.65 < 0.70 > 0.65 < 0.70 | 021 345 190 300 000 | 080 000 014 000 065 | 080 000 014 000 070 | 085 180 677 000 000 |
| 19 | 2 | 24/26 22 | 0.25/0.15 0.38 | > 0.65 < 0.70 > 0.65 < 0.70 | 021 345 190 300 000 | 080 000 014 000 065 | 080 000 014 000 070 | 085 180 677 000 000 |
| 15 | 3 | 24/26 22 | 0.25/0.15 0.38 | > 0.65 < 0.70 > 0.90 < 0.95 | 021 345 174 300 000 | 080 000 014 000 065 080 000 014 000 090 | 080 000 014 000 070 080 000 014 000 095 | 085 180 689 000 000 |
| 24 | 3 | 24/26 22 | 0.25/0.15 0.38 | > 0.65 < 0.70 > 0.65 < 0.70 | 021 345 191 300 000 021 345 190 300 000 | 080 000 014 000 065 | 080 000 014 000 070 | 085 180 677 000 000 |
| 27 | 3 | 24/26 22 | 0.25/0.15 0.38 | > 0.65 < 0.70 > 0.65 < 0.70 | 021 345 191 300 000 021 345 190 300 000 | 080 000 014 000 065 | 080 000 014 000 070 | 085 180 677 000 000 |

Special Contact Configuration

| Position | Size | AWG | mm ² | Adjustments for Crimp Tool 080.000.014.000.000 | Positionier for Socket and/or Pin Contact | Gauge Pin (for Adjustment) | | Insertion Tool |
|----------|------|-------------|-------------------|---|--|--|--|---------------------|
| | | | | | | minimum | maximum | |
| 8 | 1 | 24/26 22 | 0.25/0.15 0.38 | > 0.65 < 0.70 > 0.65 < 0.70 | 021 345 187 300 00 | 080 000 014 000 065 | 080 000 014 000 070 | 085 180 677 000 000 |
| 2 | 2 | 16 | - | >1.40 <1.45 | 021 345 196 300 000 | 080 000 014 000 140 | 080 000 014 000 145 | 085 182 707 000 000 |
| 3 | 2 | 18 | 1.0 | > 1.10 < 1.15 | 021 345 188 300 000 | 080 000 014 000 110 | 080 000 014 000 115 | 085 180 955 000 000 |
| 6 | 2 | 18 | 1.0 | > 1.10 < 1.15 | 021 345 188 300 000 | 080 000 014 000 110 | 080 000 014 000 115 | 085 180 955 000 000 |
| 8 | 2 | 24/26 22 | 0.25/0.15 0.38 | > 0.65 < 0.70 > 0.90 < 0.95 | 021 345 174 300 000 | 080 000 014 000 065 080 000 014 000 090 | 080 000 014 000 070 080 000 014 000 095 | 085 180 691 000 000 |
| 10 | 2 | 24/26 22 | 0.25/0.15 0.38 | > 0.65 < 0.70 > 0.90 < 0.95 | 021 345 174 300 000 | 080 000 014 000 065 080 000 014 000 090 | 080 000 014 000 070 080 000 014 000 095 | 085 180 691 000 000 |
| 12 | 2 | 24/26 22 | 0.25/0.15 0.38 | > 0.65 < 0.70 > 0.65 < 0.70 | 021 345 173 300 000 | 080 000 014 000 065 | 080 000 014 000 070 | 085 180 676 000 000 |
| 7 | 3 | 16 | - | - | - | - | - | 085 182 707 000 000 |
| 8 | 3 | 22 18 | 0.38 1.0 | > 1.05 < 1.10 > 1.10 < 1.15 | 021 345 183 300 000 | 080 000 014 000 105 080 000 014 000 110 | 080 000 014 000 110 080 000 014 000 115 | 085 180 955 000 000 |
| 14 | 3 | 24/26 22 | 0.25/0.15 0.38 | > 0.65 < 0.70 > 0.90 < 0.95 | 021 345 172 300 000 | 080 000 014 000 065 080 000 014 000 090 | 080 000 014 000 070 080 000 014 000 095 | 085 180 689 000 000 |
| 18 | 3 | 24/26 22 | 0.25/0.15 0.38 | > 0.65 < 0.70 > 0.90 < 0.95 | 021 345 172 300 000 | 080 000 014 000 065 080 000 014 000 090 | 080 000 014 000 070 080 000 014 000 095 | 085 180 689 000 000 |
| 20 | 3 | 24/26 22 | 0.25/0.15 0.38 | > 0.65 < 0.70 > 0.65 < 0.70 | 021 345 172 300 000 | 080 000 014 000 065 | 080 000 014 000 070 | 085 180 676 000 000 |
| 22 | 3 | 24/26 22 | 0.25/0.15 0.38 | > 0.65 < 0.70 > 0.65 < 0.70 | 021 345 191 300 000 021 345 190 300 000 | 080 000 014 000 065 | 080 000 014 000 070 | 085 180 677 000 000 |
| 26 | 3 | 24/26 22 | 0.25/0.15 0.38 | > 0.65 < 0.70 > 0.65 < 0.70 | 021 345 191 300 000 021 345 190 300 000 | 080 000 014 000 065 | 080 000 014 000 070 | 085 180 677 000 000 |

Adjustment of the Crimp Tongs 080.000.037.000.000 and 080.000.038.000.000

(see page 66)



1. Fasten the Positioner on the Crimp Tong



Please fasten the Positionier under consideration of the guiding into the tong



037: Thereby push the positionier down and turn it right at the same time.

038: You don't have to do this with this tong.



037: To fix the positionier in this position, you have to use the attached safety pin.

038: Here you have to fix the positionier with some attached allen screw and the suitable spanner.

2. Einstellen der Crimpzange auf Kabelquerschnitt



Please turn the adjustment wheel onto the right position (see page 67). If the adjustment is done, so please fix the wheel with the attached safety pin.

Now the tong is ready adjusted. You can start with the crimp process

Adjustment of the Crimp Tong 080.000.014.000.000

(see page 66)



1. Positionierer an der Crimpzange befestigen



Please insert the positionier into the tong.

Attention: The positionier is labeled with a "S" (=Socket) on the one, and with a "P" (=Pin) on the other side. So if your contact is a socket, so please insert the S-face into the tong. If your contact is a pin, so please insert the P-face into the tong.



Now you have to insure the positionier with a clamp. Fix the clamp with the screw driver.

2. Adjustment of the Crimp Tong for the cable cross section



At first you have to loose the securing nut of the setscrew. Therefore please use the attached spanner.

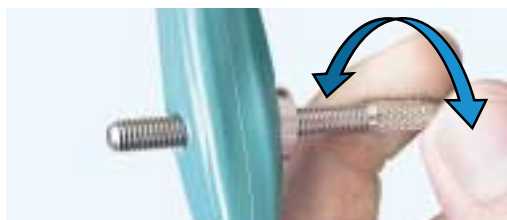

With turning on the setscrew you can adjust the cable cross section. Therefore you have to close the crimp tong completely.



With the gauge pins you have to prove the cable cross section. If the smaller gauge pin fit trough the hole in the crimp dies, and the bigger one not, the the tong is ready adjusted. Please insure the adjustment with the securing nut. Now you can start with the crimp process.

ODU MINI-SNAP PC Crimp Instruction

Suitable for the tongs 080.000.014.000.000, 080.000.037.000.000, 080.000.038.000.000,



1. Crimp the Wire into the Contact.



Insert the contact in the tong. Put the stripped wire into the termination funnel (stripping length see next page).



Close the tong completely and the crimp is done. Now you can pull out the crimped contact.

2. Press the crimped Contact into the insulation body.



Put the contacts under consideration of the pos. numbering into the insulation body. Therefore please use the assembly jig.



With the corresponding insertion tool (order information see page 67-68) you can press in the contacts into the insulation body until it snap in.



Now the assembled insert is ready.

Cable Preparation:

The following Table provides recommended guidelines for cable preparation:

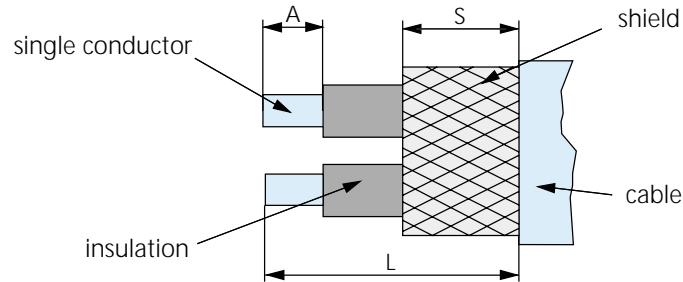

A = Stripping length single conductor
 L = Stripping length cable jacket
 S = Stripping length braided shield

| Size | Type | Contact Ø | Solder Termination | | | Crimp Termination | | |
|--------|-------|--------------|--------------------|-----|-----|-------------------|-----|-----|
| | | | L | A | S | L | A | S |
| Size 1 | A & C | 0,5 | 9 | 2,5 | 2,5 | – | – | – |
| | | 0,7 | 9 | 2,5 | 2,5 | 13 | 3,5 | 2,5 |
| | | 0,9 | 9 | 2,5 | 2,5 | 13 | 3,5 | 2,5 |
| | | 1,3 | 9 | 2,5 | 2,5 | 13 | 3,5 | 2,5 |
| | B & D | 0,5 | 13 | 2,5 | 2,5 | – | – | – |
| | | 0,7 | 13 | 2,5 | 2,5 | 17 | 3,5 | 2,5 |
| | | 0,9 | 13 | 2,5 | 2,5 | 17 | 3,5 | 2,5 |
| | | 1,3 | 13 | 2,5 | 2,5 | 17 | 3,5 | 2,5 |
| Size 2 | A & C | 0,7 | 14 | 2,5 | 2,5 | 15 | 3,5 | 2,5 |
| | | 0,9 | 11 | 2,5 | 2,5 | 15 | 3,5 | 2,5 |
| | | 1,3 | 11 | 2,5 | 2,5 | 15 | 3,5 | 2,5 |
| | | 1,6 | 11 | 2,5 | 2,5 | 15 | 3,5 | 2,5 |
| | B & D | 0,7 | 15 | 2,5 | 2,5 | 19 | 3,5 | 2,5 |
| | | 0,9 | 15 | 2,5 | 2,5 | 19 | 3,5 | 2,5 |
| | | 1,3 | 15 | 2,5 | 2,5 | 19 | 3,5 | 2,5 |
| | | 1,6 | 15 | 2,5 | 2,5 | 19 | 3,5 | 2,5 |
| Size 3 | A & C | 0,7 | 14 | 2,5 | 2,5 | 18 | 3,5 | 2,5 |
| | | 0,9 | 14 | 2,5 | 2,5 | 18 | 3,5 | 2,5 |
| | | 1,3 | 14 | 2,5 | 2,5 | 18 | 3,5 | 2,5 |
| | | 1,6 | 14 | 2,5 | 2,5 | 24 | 3,5 | 2,5 |
| | | 2,0 | 20 | 2,5 | 2,5 | 24 | 3,5 | 2,5 |
| | B & D | 0,7 | 20 | 2,5 | 2,5 | 24 | 3,5 | 2,5 |
| | | 0,9 | 20 | 2,5 | 2,5 | 24 | 3,5 | 2,5 |
| | | 1,3 | 20 | 2,5 | 2,5 | 24 | 3,5 | 2,5 |
| | | 1,6 | 20 | 2,5 | 2,5 | 24 | 3,5 | 2,5 |
| | | 2,0 | 20 | 2,5 | 2,5 | 24 | 3,5 | 2,5 |

All dimensions in mm

Tolerance: + 10 %

Exceptions are noted on special instructions.
 Right-angle plugs have special instructions.

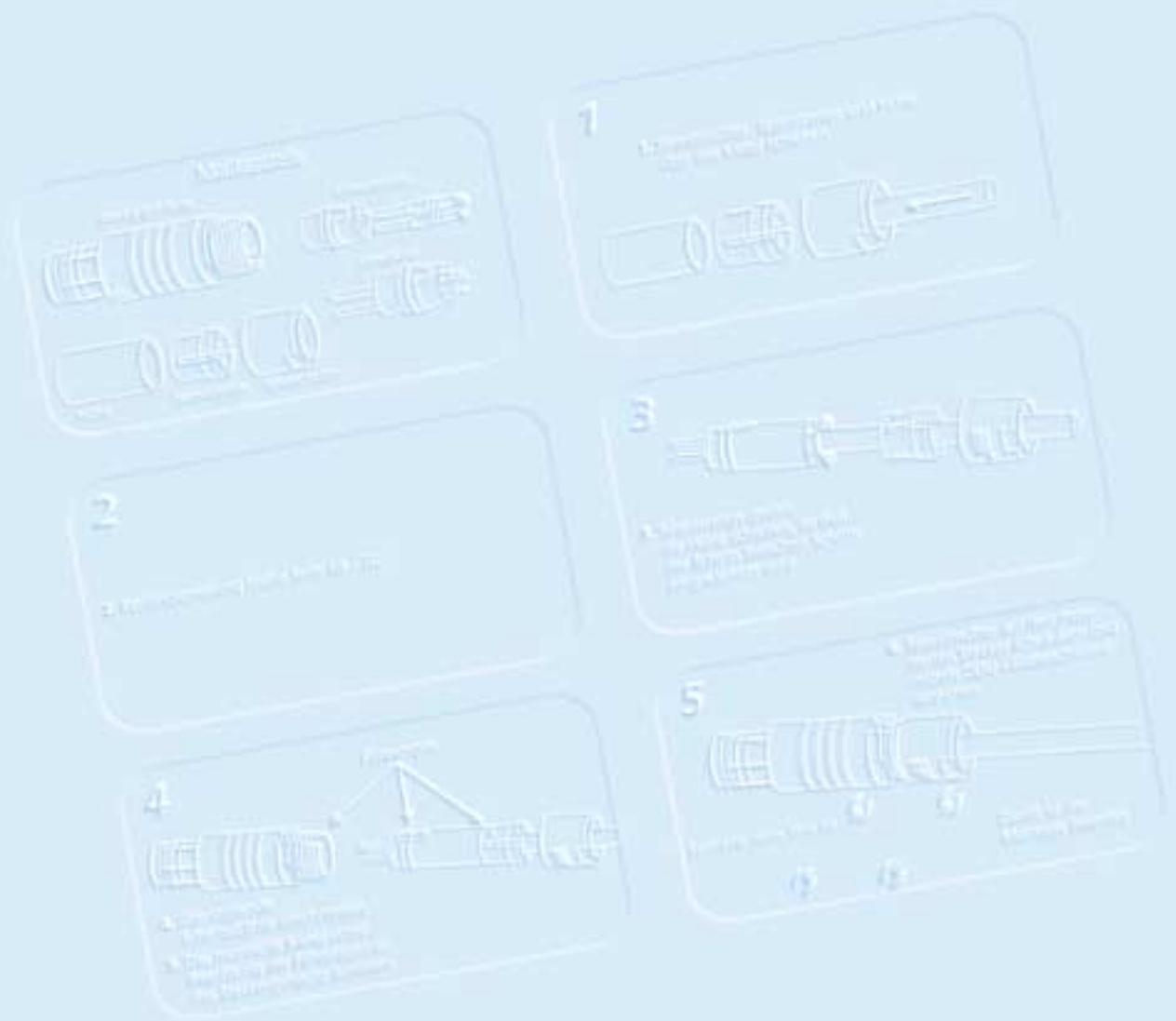

Assembly Instructions

Assembly Instructions

For plugs with plastic inner parts (IP 50) Type B and D

Screw locking with glue.
Recommended glue:
Scotch Weld DP 190

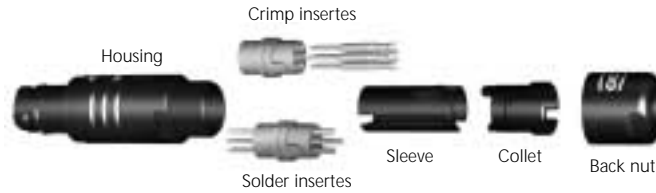

1. Slide back nut, collet and sleeve over the cable.

Crimp termination



Part number see page 66

2. Strip cable and wire
3. Fit wire into the contact barrel and crimp



Part number see page 67 and 68

4. insert contacts into insulator, use the insertion tool to push them in

Solder termination



2. Strip cable and wire
3. Pre-tinning of strands recommended



4. Solder each wire to the corresponding contact



5. Bend cable shield outwards.



6. Slide the collet against the sleeve and clamp the shield between it.

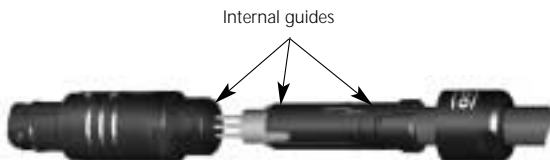

Internal guides

7. Now you can put the assembled cable into the plug-housing.



8. Screw back nut on the plug and fasten cable in the housing. *
Now the plug is assembled.

* ODU Spanner-Wrench: see page 63

Assembly Instructions

For plugs with metal inner parts (IP 68) Type A and C

Screw locking with glue.
Recommended glue:
Scotch Weld DP 190

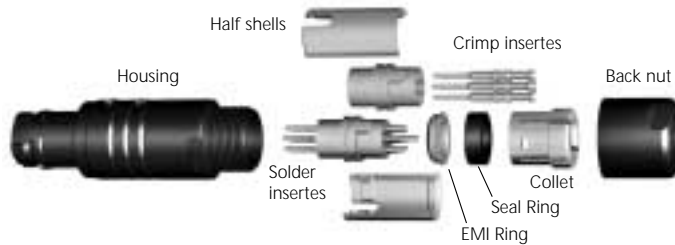

1. Slide Back nut, Collet, Seal Ring and EMI-Ring over the cable.

Crimp termination



Part number see page 66

2. Strip cable and wire
3. Fit wire into the contact barrel and crimp



Part number see page 67 and 68

4. insert contacts into insulator, use the insertion tool to push them in



Half shells



Internal guides

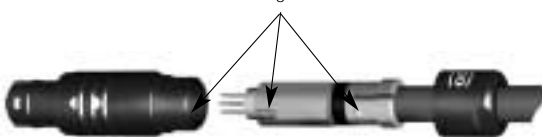

Solder termination



2. Strip cable and wire
3. Pre-tinning of strands recommended



Solder iron

4. Solder each wire to the corresponding contact

5. Bend cable shield outwards.

6. Slide the EMI-Ring against the sleeve and clamp the shield between it.

7. Now you can put the assembled cable into the plug-housing.

8. Screw back nut on the plug and fasten cable in the housing. *
Now the plug is assembled.

* ODU Spanner-Wrench: see page 63

Standard Packing

- Plug

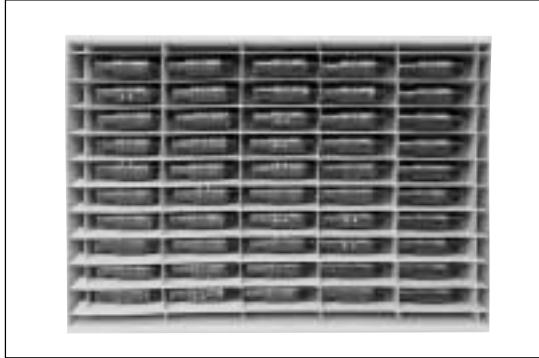

Housing

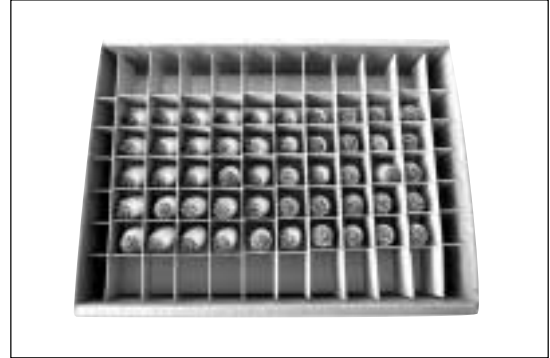

Contact Inserts



Back Nut



Accessories (Collet nuts, Cable Bend Reliefs etc.)

- Receptacles



Receptacles with Solder- and PCB-Contacts

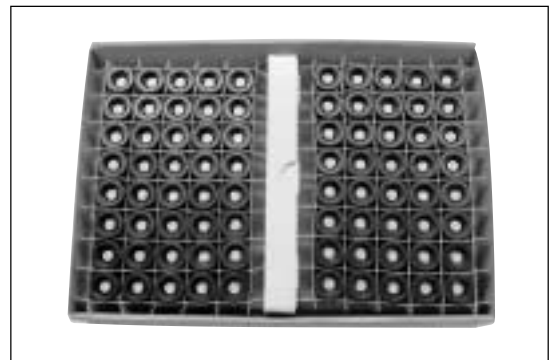

Receptacles with Crimp-Contacts

There are different packings possible, due to different sizes, quantities, styles ect.



General Technical Informations

International Protection (IP) Classes DIN EN 60 529 (respectively IEC 529 / VDE 0470 T1)

The housing and the locking system of the ODU MINI-SNAP PC protect the contacts against outside mechanical influence, such as impact shocks, impurities, dust, unintended contact and penetration of moisture, water or other liquids (coolants, oils, etc.).

Protection classification is indicated with the letters **IP** and two numbers.

IP: International Protection















All IP 68 submersible ODU MINI-SNAP PC Connectors are rated to 2 m water depth (0,2 bar) for 24 hours in accordance with DIN EN 60529.

A watertight plug requires a cable grommet in the collet. The grommet has to fit tightly over the cable.

The cable jacket must be smooth, cylindrical and free of grooves.

The plug should be potted for watertightness in unmated condition.

(Higher requirements for Watertightness on request)

| Code letters (International Protection) | | First Index Figure (Foreign bodies protection) | Second Index Figure (Water protection) | |
|--|--|---|---|---|
| IP | | 6 | 8 | |
| Index | Degree of protection | Index | Degree of protection | |
| 0 |  No protection against accidental contact, no protection against intrusion of solid foreign bodies | 0 |  | No protection against water |
| 1 |  Protection against contact with any large area by hand and against large solid foreign bodies with $\varnothing > 50$ mm | 1 |  | Protection against vertical water drips |
| 2 |  Protection against contact with the fingers, protection against large solid foreign bodies with $\varnothing > 50$ mm | 2 |  | Protection against water drips (up to a 15° angle) |
| 3 |  Protection against tools, wires or similar objects with $\varnothing > 2,5$ mm. Protection, against small foreign solid bodies with $\varnothing > 2,5$ mm | 3 |  | Protection against diagonal water drips (up to a 60° angle) |
| 4 |  As 3 however $\varnothing > 1$ mm | 4 |  | Protection against splashed water from all directions |
| 5 |  Full protection against contact. Protection against interior detrimental dust deposition. | 5 |  | Protection against water spray from all directions |
| 6 |  Total protection against contact. Protection against intrusion of dust | 6 |  | Protection against temporary flooding |
| | | | 7 | Protection against temporary immersion |
| | | | 8 | Protection against water pressure |

In accordance with DIN VDE 0470, DIN EN 60 529, IEC 529
Source: ZVEI = German Association of the Electrotechnical and Electronic Industry e.V.

Insulation Groups / Nominal Voltage / Test Voltage

Insulation Groups in accordance with DIN VDE 0110 T1, (1989-01)

Groups of connectors based on ambient and operating conditions.

Example :

A connector used in a shop environment falls into Group B. (Laboratory environment would fall into Group A).

Insulation Group A0 :

For low power equipment in climate-controlled and dry rooms with only minimal heat rise when subjected to short circuit conditions.

Insulation Group A :

For equipment operated in climate-controlled and dry rooms.

Insulation Group B :

For equipment operated in living quarters, offices, and other commercial environments. Also for clean machine shops, laboratories, test stands, and medical environments.

Insulation Group C :

Equipment primarily operated in industrial, commercial, and agricultural establishments. Non climate-controlled warehouses, workshops, boiler rooms, and manufacturing floors.

Insulation Group D :

Equipment operated on vehicles subjected to dirt, brake dust, and splash water or snow. Unprotected by housing.

Determination of Nominal Voltage from Test Voltage in accordance with VDE 0627

The following explains how to derive the nominal voltage from the test voltage. (For practical purposes nominal voltage, rated voltage, and reference voltage are the same.)

The operating voltage must be less than the nominal voltage. A clear definition can be found in DIN VDE 0110, page 84.

Example :

The selected connector has a test voltage of 1,000 VAC and will be operated in a clean mechanical shop environment (Insulation Group B)

According to the Table 3 below, the connector has a nominal voltage of 150 VDC. (The example shows both printed in **bold**.)

Table 3 from DIN VDE 0627

| Reference Voltage / Nominal Voltage in Volt | | Test Voltage in Volt (AC 50 Hz) | | | | |
|---|--------------|---|------|-------------|------|------|
| in Volt (DC) | in Volt (AC) | Insulation Group | | | | |
| | | A0 | A | B | C | D |
| 15 | 12 | 375 | 500 | 750 | 875 | 1250 |
| 36 | 30 | 500 | 500 | 750 | 1000 | 1500 |
| 75 | 60 | 500 | 625 | 875 | 1000 | 1500 |
| 150 | 125 | 625 | 750 | 1000 | 1250 | 1750 |
| 300 | 250 | 750 | 875 | 1250 | 1750 | 2250 |
| 450 | 380 | 875 | 1000 | 1750 | 2250 | 3000 |
| 600 | 500 | 1000 | 1250 | 2000 | 2750 | 3500 |
| 800 | 660 | 1250 | 1750 | 2500 | 3500 | 4000 |
| 900 | 750 | 1500 | 1750 | 2750 | 3500 | 4500 |
| 1200 | 1000 | 1750 | 2250 | 3500 | 4500 | 5500 |



Operating voltage acc. to SAE AS 13441-method 3001.1

The values acc. to SAE AS 13441-method 3001.1 comply with MIL-Std. 1344 – method 3001.

The chart values results are acc. to IEC 60512. The inserts have been tested in mated condition and the test voltage was applied to the pin insert.

75% of the measured break-down voltage is the basic for the further calculation. 1/3 of this value is the corresponding operating voltage.

All tests were performed at standard environment conditions (room temperature) and can be applied up to an altitude of 2000 m.

For any deviations one has to consider the reduction factor acc. to the relevant standards.

Test voltage: Break-down voltage x 0,75

Operating voltage: Break-down voltage x 0,75 x 0,33

Caution:

Electrical appliances: for various applications the safety requirements regarding the operating voltage is even more severe!

The relevant data in such cases for the operating voltage are the creepage and clearance distances. For any advise how to chose the proper connector please consult us and indicate the safty standard which your product has to meet.

Termination Styles

Contact blocks (insulation bodies with contacts) are interchangeable between receptacle and plug. As a rule the socket contact blocks are mounted in the part under power.

ODU offers the following contact termination styles:

- Solder
- Crimp
- PCB

Termination Styles for Turned Contacts

Solder Termination:

The contacts come mounted by the factory. The insulation body and the pre-assembled contacts are called a contact block.



Crimp Termination:

A single contact is crimped to a single conductor. Subsequently, the crimped contact is pushed into the insulation body. Crimp contacts and insulation bodies are shipped separately.

Crimping creates a reliable, corrosion-free and durable connection between the contact and the conductor.

Crimping causes the crimp barrel of the contact and the conductor material to cold flow. It creates a gas-tight connection between contact and conductor.

The ODU MINI-SNAP generally requires the industry-standard 8-point crimp tool .



Printed Circuit Board (PCB) Termination:

PCB pins are used only for receptacles which are mounted directly to the PCB. The contacts are permanently installed in the insulation body.



Termination Styles for Stamped and Formed Contacts

Solder Termination

The contacts come mounted by the factory. The contacts are fixed in the insulating body before the single wires are assembled. The insulating body together with the pre-assembled contacts is called the insert. The termination area of the contact shows a solder stop.



Crimping Termination

The single contacts are connected to the wires by deformation of the connecting area (crimping). After this the single contacts are inserted into the insulation body. This assembly can be carried out by hand without additional tools. Accordingly for crimping termination no complete inserts are supplied. Insulating bodies and contacts on a carrier tape are separate.

The crimping termination insures a permanent, corrosion-free and contact safe connection.

The cold crimping process allows to realise a gas tight connection between the wire and the contact material, which at the same time gives the strain relief.

The crimp contact generally uses the F-Crimp.



Cross Section F-Crimping

PCB Termination

The contacts come mounted by the factory. This connection is used only for the receptacle when this part is mounted and soldered directly to the PCB.



Conversion: AWG to Metric

AWG = American Wire Gauge

The AWG system describes the cross section of a wire using a gauge number for every 26 % increase in conductor cross section. With larger wire diameters, the AWG gauge numbers decrease; as the wire sizes increase, the AWG gauge numbers decrease.

Most wires are made with **stranded conductors**. Compared to solid conductors stranded wires offer higher durability, higher flexibility and better performance under bending and vibration.

Stranded wires are made from wires with smaller gauge sizes (higher AWG gauge number). The AWG gauge number of the stranded wire is equal to that of a solid conductor of the same size wire. The cross section of the stranded conductor is the sum of cross sections of the single conductors.

For example, a AWG-20 stranded wire of 7 AWG-28 conductors has a cross section of 0.563 mm²; an AWG-20 stranded wire with 19 AWG-32 conductors has a cross section of 0.616 mm².

Conversion Table AWG / mm²

| Circular Conductor | | | | | |
|--------------------|----------|--------|----------------------------------|-----------------|-------------------------|
| AWG | Diameter | | Cross Section mm ² | Weight kg/km | max. Resistance Ω/km |
| | in | mm | | | |
| 10 (1) | 0,102 | 2,59 | 5,27 | 47,0 | 3,45 |
| 10 (37/26) | 1,109 | 2,75 | 4,53 | 43,6 | 4,13 |
| 12 (1) | 0,0808 | 2,05 | 3,31 | 29,5 | 5,45 |
| 12 (19/25) | 0,0895 | 2,25 | 3,08 | 28,6 | 6,14 |
| 12 (37/28) | 0,0858 | 2,18 | 2,97 | 26,3 | 6,36 |
| 14 (1) | 0,0641 | 1,63 | 2,08 | 18,5 | 8,79 |
| 14 (19/27) | 0,0670 | 1,70 | 1,94 | 18,0 | 9,94 |
| 14 (37/30) | 0,0673 | 1,71 | 1,87 | 17,4 | 10,5 |
| 16 (1) | 0,0508 | 1,29 | 1,31 | 11,6 | 13,94 |
| 16 (19/29) | 0,0551 | 1,40 | 1,23 | 11,0 | 15,7 |
| 18 (1) | 0,0403 | 1,02 | 0,82 | 7,32 | 22,18 |
| 18 (19/30) | 0,0480 | 1,22 | 0,96 | 8,84 | 20,4 |
| 20 (1) | 0,032 | 0,813 | 0,52 | 4,61 | 35,1 |
| 20 (7/28) | 0,0366 | 0,93 | 0,56 | 5,15 | 34,1 |
| 20 (19/32) | 0,0384 | 0,98 | 0,62 | 5,45 | 32,0 |
| 22 (1) | 0,0252 | 0,64 | 0,324 | 2,89 | 57,7 |
| 22 (7/30) | 0,0288 | 0,731 | 0,354 | 3,24 | 54,8 |
| 22 (19/34) | 0,0307 | 0,780 | 0,382 | 3,41 | 51,8 |
| 24 (1) | 0,0197 | 0,50 | 0,196 | 1,83 | 91,2 |
| 24 (7/32) | 0,023 | 0,585 | 0,227 | 2,08 | 86,0 |
| 24 (19/36) | 0,0252 | 0,640 | 0,240 | 2,16 | 83,3 |
| 26 (1) | 0,157 | 0,40 | 0,122 | 1,14 | 147,0 |
| 26 (7/34) | 0,0189 | 0,48 | 0,140 | 1,29 | 140,0 |
| 26 (19/38) | 0,0192 | 0,487 | 0,15 | 1,40 | 131,0 |
| 28 (1) | 0,0126 | 0,32 | 0,08 | 0,716 | 231,0 |
| 28 (7/36) | 0,015 | 0,381 | 0,089 | 0,813 | 224,0 |
| 28 (19/40) | 0,0151 | 0,385 | 0,095 | 0,931 | 207,0 |
| 30 (1) | 0,0098 | 0,250 | 0,0506 | 0,451 | 374,0 |
| 30 (7/38) | 0,0115 | 0,293 | 0,055 | 0,519 | 354,0 |
| 30 (19/42) | 0,0123 | 0,312 | 0,072 | 0,622 | 310,0 |
| 32 (1) | 0,0080 | 0,203 | 0,032 | 0,289 | 561,0 |
| 32 (7/40) | 0,0094 | 0,240 | 0,035 | 0,340 | 597,1 |
| 32 (19/44) | 0,0100 | 0,254 | 0,044 | 0,356 | 492,0 |
| 34 (1) | 0,0063 | 0,160 | 0,0201 | 0,179 | 951,0 |
| 34 (7/42) | 0,0083 | 0,211 | 0,0266 | 0,113 | 1491,0 |
| 36 (1) | 0,0050 | 0,127 | 0,0127 | 0,072 | 1519,0 |
| 36 (7/44) | 0,0064 | 0,163 | 0,0161 | 0,130 | 1322,0 |
| 38 (1) | 0,0040 | 0,100 | 0,0078 | 0,072 | 2402,0 |
| 40 (1) | 0,0031 | 0,080 | 0,0050 | 0,043 | 3878,6 |
| 42 (1) | 0,0028 | 0,0700 | 0,0038 | 0,028 | 5964,0 |
| 44 (1) | 0,0021 | 0,054 | 0,0023 | 0,018 | 8660,0 |

(Source: Gore & Associates, Pleinfeld)



Quality Management at ODU

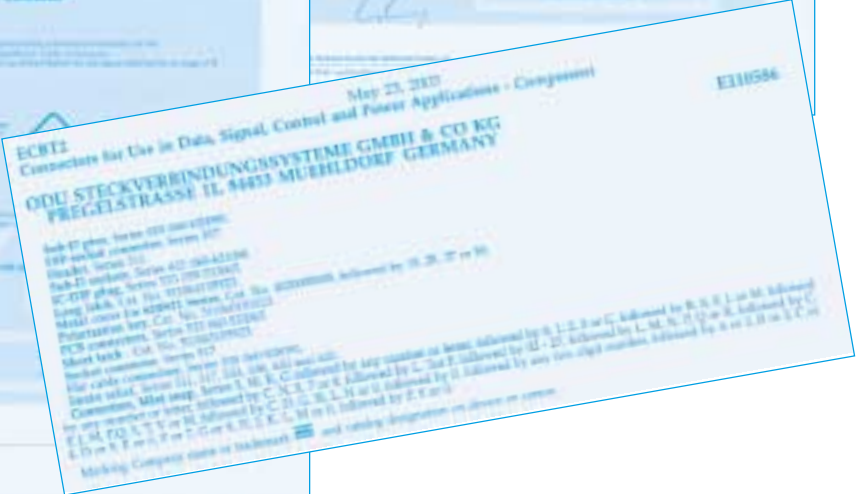

Technical Terms and Definitions

Air Gap

= Shortest distance between two conductive elements through the air.

Autoclavability

(See page 59)

AWG

(See page 83)

Creepage Distance

= The distance measured across the surface of a dielectric between two contacts or a contact and a metal part. The longer the distance, the lesser the risk of damage or tracking. Minimum creepage distances are specified according to the operating voltage and the applicable isolation group.

Crimp Area

= The part of a crimp barrel at which the crimp connection is achieved by pressure deformation or by reshaping the barrel around the conductor.

Crimp Barrel

A hollow part of a contact which accepts one or more conductors and which may be crimped through the application of a crimping tool.

Crimp Connection

= The permanent attachment of a contact to a conductor by pressure deformation or by reshaping the crimp barrel around the conductor so that a good electrical and mechanical connection is established.

(See page 82-83)

Connector

= A component which terminates conductors for the purpose of providing connection and disconnection to a suitable mating component. Depending on the fastening to a cabinet, panel, rack etc. or a cable, they are classification.

Delivery

Delivery of the connectors usually as components (that means not assembled).

Exception: Solder contacts are factory-installed in the insulation body.

Fixed Connector

= A connector for attachment to a rigid surface (panel).

Free Connector

= A connector for attachment to the free end of a wire or cable. Also called free hanging connector or inline receptacle.

Insertion Or Withdrawal Force

= The force required to fully mate or unmate a set of connectors without the effect of coupling, locking or similar devices. The insertion force is usually greater than the withdrawal force. Also called mating and unmating force.

Insulation Body

= Non-conductive part of a connector, to electrically and mechanically separate live parts and to protect against accidental touch.

Insulation Group

= Classification of connectors according to the operating and working conditions (see page 79 insulation groups according DIN VDE 0110).

Keying

= System of projections and grooves on mating connectors which prevent otherwise identical connectors from being mated. This is useful when several connectors of the same style are used in the same application.

Lower Limit Temperature

= The lowest permissible temperature which a connector or a plug-in device is allowed to be operated.

Materials

(see page 56).

Mating Cycles

= Mechanical operation of connectors and plug-in devices by insertion and withdrawal. One mating cycle comprises one insertion and one withdrawal operation.

Nominal Single Contact Current Load

= Current load, which can load every single contact (see page 54-55).

Nominal Voltage

Nominal voltage characterizes a component.

Operating Temperature of the ODU MINI-SNAP

= Range between upper and lower temperature limits.

- 40 °C to + 120 °C (see page 10)

Print Connection

(see page 82-83)

Printed Circuit Board

Boards, typically made of epoxy-filled glass fiber fabric, with conductive pattern on one or both sides, or in case of multilayer boards, also imbedded inside the board. They feature metallized holes for soldering wire-mounted components or for the insertion of resilient or rigid press-in pins or instead, pads for attaching components using surface mount technology (SMT).

Reference Current

= The current at which a connector can be operated permanently simultaneously through all contacts without reaching maximum temperature.

Reference Voltage

Normal voltage (VDE 0110) for a connector (see page 81).

Solder Termination

(see page 82-83)

Termination techniques

= Methods for connecting a wire to an electro-mechanical component, e.g. solderless connection according to IEC 60352: respectively such as crimp, press-in etc. or solder connections.

Test Voltage

= The voltage the connectors are tested, and are being referred on definite characteristics (see page 81).

Upper Limit Temperature

= highest permissible temperature at which a connector or a plug-in device is allowed to operate. This temperature includes the self-heating and the ambient temperature. At ODU MINI-SNAP + 120 °C (see page 54-55).

Watertightness

(See page 80)

**Wire**

= Wires may be provided with an insulation cover, an electrical shielding. Cables or conductors may consist of one or more wires.

Connectors shown in this catalog are designed to operate at high voltages and high frequencies. Care must be taken to assure that no person can come in contact with live conductors during installation or operation of the connectors.

ODU assured that at the time of print all information in this catalog was correct. ODU reserves the right to change design and performance of any product to meet changing technical developments without prior notice. ODU reserves the right to discontinue any part in this catalog without prior notice and without obligation to continue production after the change.







Please open

Part Number Key

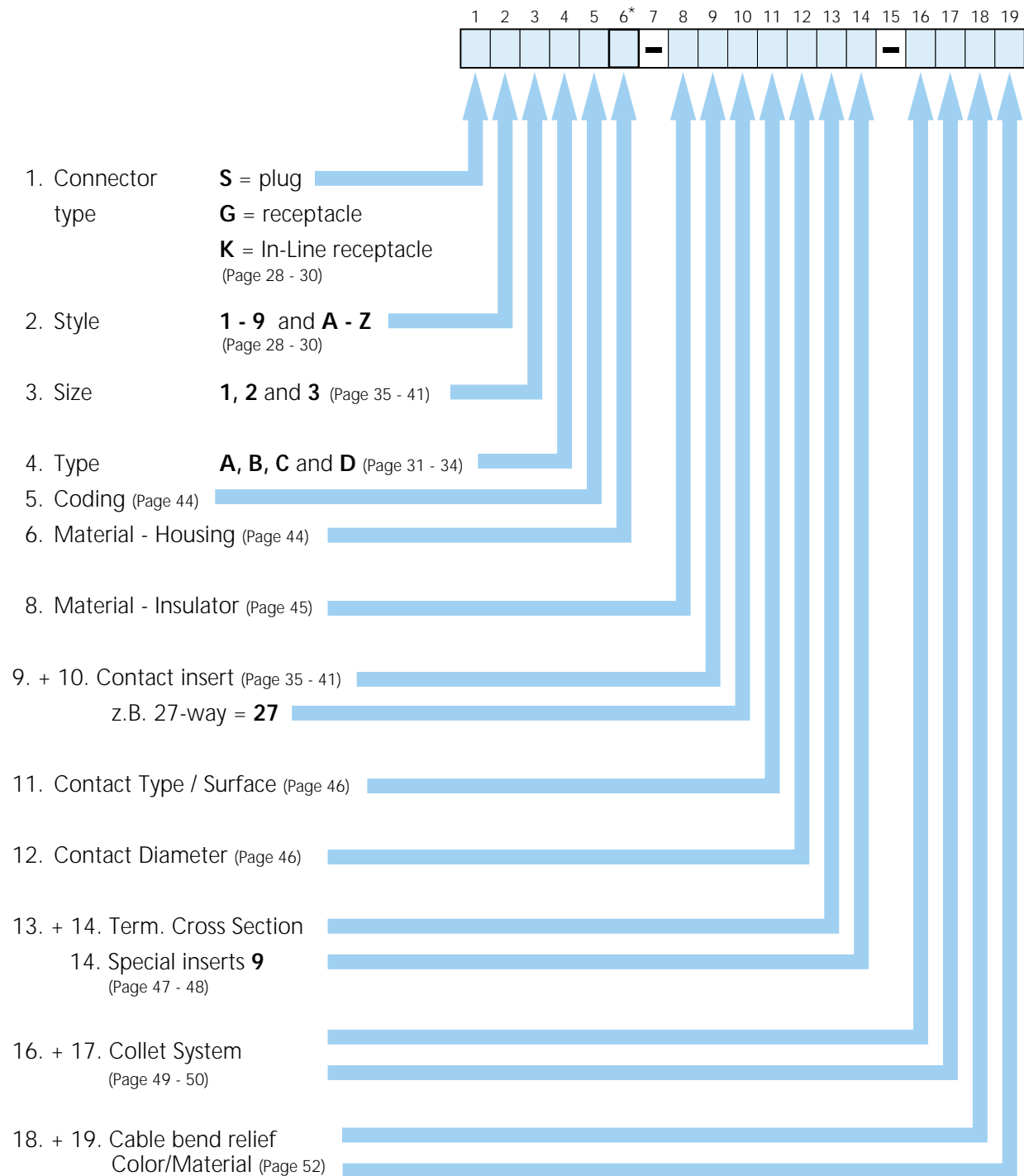

Example:

| 1 | 2 | 3 | 4 | 5 | 6 | 7 | 8 | 9 | 10 | 11 | 12 | 13 | 14 | 15 | 16 | 17 | 18 | 19 |
|---|---|---|---|---|---|---|---|---|----|----|----|----|----|----|----|----|----|----|
| S | 4 | 1 | A | 1 | 8 | - | T | 0 | 7 | 4 | F | Z | 0 | - | 4 | 5 | G | P |

Plug – IP 68 – Size 1 – Type A – Coding 1 – Black plastic housing – PBT insulator – 7-way stamped and formed Crimp-Pin – AWG 28-26 – Cable diam. 4,1-4,5 mm – Black Cable Bend Relief - Material PUR

* If in field number 6 there is a 3 or 8, and in field number 4 there is a A, B, C, or D, it can be seen right away that this product is a Push-Pull Connector of the plastic PC version.



ODU's headquarters and factory are located in Mühlendorf, at the river Inn, approximately 50 miles east of Munich, at the foothills of the Bavarian Alps.



Photo of City Mühlendorf/Inn



Mühlendorf, an idyllic small town with its typical Inn-Salzach architecture.



Werr. 05/04



2 rue René Laennec 51500 Taissy France
Fax: 03 26 85 19 08, Tel : 03 26 82 49 29

E-mail: hvssystem@hvssystem.com
Site web : www.hvssystem.com